

# A Location Tracking System Using Location Prediction and Dynamic Threshold

Janani.S<sup>[1]</sup>, Lakshmi.A<sup>[2]</sup>, Lavanya.N<sup>[3]</sup>, Mrs. K. Rejini<sup>[4]</sup>  
<sup>[1],[2],[3]</sup> UG Student, <sup>[4]</sup> Assistant Professor.

Department of Computer Science & Engineering,  
Anand Institute Of Higher Technology.

---

*Abstract* — In this paper, a real time location tracking system is developed based on GPS with foremost two techniques LBD and Dynamic threshold. Location based delivery(LBD) is used to track the moving speed of the target.LBD consists of dynamic threshold,SMS and GPS.Dynamic Threshold values can be adjusted according to the moving speed of the target. The automatic SMS is generated when the target exceeds the threshold value and sent to the target with absolute speed and accurate location .It reduces the number of short messages.SMS delivery is based on the latitude and longitude of the target location.Here the latitude and longitude are calculated using GPS. It mainly overcomes the limitations in previous time based delivery system. This paper presents a tracking Techniques application for android mobile phone user's.

*Index Terms* — Global positioning system (GPS), location tracking, prediction algorithms, short messageservice(SMS), Dynamic threshold and Location based Delivery(LBD).

---

## I. INTRODUCTION

The GPS are now available in mobile phones. Now a days it has become easier to track locations using the GPS in mobile phones. The proposed system is mainly implemented for safety purpose.The objective of this paper is achieved by using location prediction and dynamic threshold.

The GPS is used to obtain the location information of a target (e.g., a mobile device).Here the short message service(S MS) can be used to transmit the messages from target to the tracker .The message contains the information about the target's location. For example, Lee et al. proposed a real-time location tracking system [2] for childcare or elderly care. Location information of the mobile devices are transmitted to a central GPS application server through 802.11 wireless networks. So this application allows the server to simultaneously monitor multiple targets. Choi et al. assumed that the location information of a target is transmitted through wireless networks. This paper focused on proposing a geolocation update scheme to decrease the update frequency [8]. Lita et al. proposed an automobile localization system by using SMS [4]. The proposed system, which is interconnected with the car alarm system, transmits alerts to the user's mobile phone in the event of a car theft or provides information for monitoring adolescent drivers. Hameed et al.

proposed a car monitoring and tracking system that uses both SMS and GPS to prevent car theft [6]. Anderson et al. proposed a transportation information system [7]. In this system, a hardware device called StarBox, which is provided with a global system for mobile communications (GSM) modem and a GPS unit, is installed in the vehicle to track the vehicle's location. StarBox transmits short SMS containing its GPS coordinates to the server at 30-s intervals. People can send short messages to the server to determine the expected arrival time of buses at their locations. Eventhough transmitting the geolocation information of a target via wireless networks is effective when both the target and the tracker are within Wi-Fi coverage area, the 802.11 wireless networks are not always accessible. When the target or the tracker is not able to access Wi-Fi, it is not possible to perform location tracking. Therefore, SMS is a relatively high reliable and flexible solution because of its widespread use (i.e., well-structured worldwide) [7], [9]. However, SMS is a user-pay service. The purpose of this study is to minimize the transmission cost of a tracking system by minimizing the number of SMS transmissions while maintaining the location tracking accuracy.

Location based delivery(LBD) is used to track the moving speed of the target.LBD consists of dynamic threshold,SMS and GPS.Dynamic Threshold values can be adjusted according to the moving speed of the

target. It reduces the number of short messages. SMS delivery is based on the latitude and longitude of the target location. Here the latitude and longitude are calculated using GPS. Location prediction is performed by using the current location, moving speed, and bearing of target to predict its next location. When the distance between the location predicted and the actual location crosses a certain threshold, the target transmits a short message to the tracker to update its current location. The location tracking accuracy and number of short messages are maintained by dynamic threshold based on the moving speed of the target.

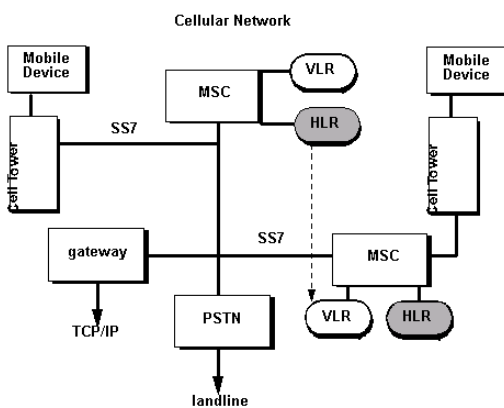

The remainder of this paper is organized as follows. Section II discusses the technical background for LBD and reviews the relevant literature, including SMS and tracking technologies. Section III elaborates on the design of LBD, while Section IV describes the LBD system developed on the basis of Android phones and demonstrates some of the graphic user interfaces (GUIs). Section V describes the experiment and its results. Conclusions and future works of the authors are discussed in the final section.

## II. TRADITION AND RELATED WORK

### A. Short Message Service

SMS stands for **short message service**. It is the method of communication that sends text between mobile phones, or from a PC or handheld to a mobile phone. The "short" part refers to the maximum size of the text messages: 160 characters. For other alphabets, like Chinese, the maximum message size is 70 characters.

The GSM network architecture as defined in the GSM specifications can be grouped into four main areas: Mobile station (MS), Base-Station Subsystem (BSS), Network and Switching Subsystem (NSS), Operation and Support Subsystem (OSS). As for the actual sending of a SMS, the text message from the sending mobile device is stored in a central SMC, which then transmits the message to its desired destination. As SMS messaging makes use of a separate channel, which is normally used transfer of control messaging to transfer the packets, voice and data calls will not be interrupted by SMS transfer. This control channel is usually used to track the cell that our phone is currently in, allowing us to change cells as you move around and so that calls and messages can be sent to the correct handsets in the correct locations.

The SMC is in charge of storing and forwarding messages to and from the mobile station and other short message entities, which is a mobile phone. The benefit of storing messages here is that several attempts can be made to deliver a message if the receiving device cannot be contacted. If the wireless recipient is switched off, out of range, or if there is a network is not available, the SMS will be stored in the network and delivered when the recipient becomes available again.

However, in order to figure out exactly where the message has to be sent, the SMC needs to be provided with the location of the recipient. This is where the Home Location Register is used. The Home Location Register is a database that contains the information of all the network's subscribers, and is responsible for matching mobiles to mobile numbers, accounts, and with service plan information. But importantly, it keeps track of the user's location so that incoming calls and messages can be routed through to the correct network tower.

Once the message knows where to go the Mobile Switching Center (MSC) is in charge of switching the connection over to the correct mobile station. There's also a Visitor Location Register (VLR) attached to each MSC, that helps to narrow down the exact location of the cell where the receiving handset is currently located. The message is then finally sent to the corresponding Base Station System (BSS).

The BSS consists of transceivers which send and receive information over the air, to and from the MS. This information is sent over the signalling channels so the mobile can receive messages even if a voice or data call is going on. The BSS is the final device that sends the text message to the correct mobile.

SMS is the most widely used data application worldwide. This proposed system uses SMS to transmit location update messages and assumes that the message delay between the tracker and the target is negligible.

### B. Tracking Technique

GPS is widely used for target location because of its high positioning accuracy [2]–[4], [7], [9]. Additionally, GPS networks are well-constructed and widely accessible. Therefore, GPS networks can be used, practically, for positioning an object by using triangulation.

Related works have roughly classified the location tracking methods [3], [5], [6], [8], [9] using GPS and SMS as time-based delivery and distance-based delivery. Time-based delivery is used to periodically transmit location update messages for tracking [3], [6], [10]. By contrast, distance-based delivery is used to transmit location update messages when the distance between the previously reported location and the current location exceeds a fixed-distance threshold [9]. Time-based delivery is effective for tracking a target that is moving erratically. However, it exhibits a major disadvantage when the target remains stationary for an extended period, that is, it continues to periodically transmit many unnecessary short messages. However, SMS is a user-pay service. Therefore, the objective of this study is to minimize the number of SMS transmissions while simultaneously maintaining the location tracking accuracy.

The proposed system differs from distance based delivery. It is mainly based on two techniques: location based delivery and dynamic threshold. In this approach message is transmitted to the tracker only when it exceeds certain threshold value. LBD also reduces the number of messages when compared with DBD. The tracker periodically updates the location of the target on the local screen according to the predicted location. But when it receives a short message response from the target, it means that the predicted location is far from the actual location. For more accurate tracking, the tracker updates the target's location using information encoded in the received message, rather than its prediction.

#### 1. Defined SMS format.,

- (a) SMS query (total 13 or 14 bytes)

P(6)	;	T(1)	;	A(4or5)
------	---	------	---	---------

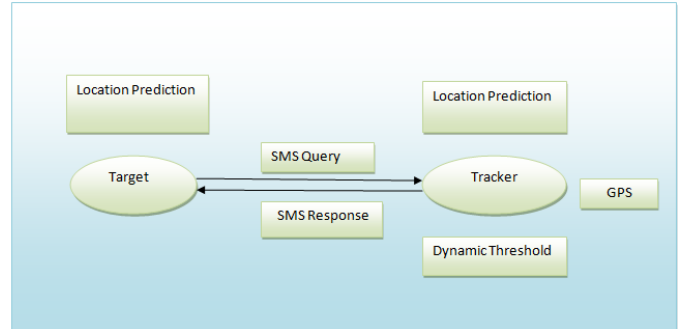

Structure of LBD system

#### A. Well-Defined SMS Format

The designed messages are of two types: SMS query and SMS response. The SMS query includes three fields: Prefix (P), type (T), and action (A). The SMS response includes six fields: Prefix (P), type (T), latitude (La), longitude (Lo), speed (S), and bearing (B), as listed in Table 1(b). The fields are separated by a semicolon.

The prefix field containing the 6-character "TraSMS" indicates that the message is particularly used for location tracking. The two supported types are query (denoted as Q) and response (denoted as R). The SMS query includes two commands, Start and Stop, which represents the starting and stopping of the tracking action, respectively. In the SMS response, the latitude and longitude fields contain the GPS latitude and longitude information of a target, respectively. The speed field contains the target speed information in meters/hour. Finally, the bearing field stores the bearing data obtained from the GPS. All the fields listed in Table 1 are of fixed lengths according to their possible values in real time. For example, the latitude field is 11 bytes long because it stores the latitude information, for example, 53°11 18 N.

"TraSMS;Q;Start" SMS query informing the target of the tracking action. When the target receives the SMS query, it transmits the SMS response when necessary (e.g., when the distance exceeds a certain threshold). The SMS response contains the current location information of the target, such as latitude, longitude, bearing and speed.

For an SMS query, the start and end tracking messages are 14 and 13 characters long, respectively. By contrast, an entire SMS response is 52 characters long. The defined message format can fit into a single short message because the length of a short message can be up to 140, 8-bit characters.

### B. Location Prediction

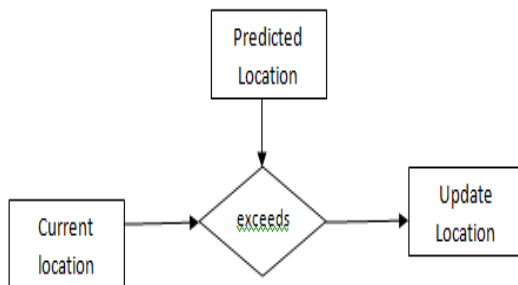

The location prediction module is built in both the target and the tracker side, uses the information of the current location. It is performed by using the current location, moving speed, and bearing of target to predict its next location. When the distance between the location predicted and the actual location crosses a certain threshold, the target transmits a short message to the tracker to update its current location.

The distance exceeds the threshold, i.e.,  $D > TH$ , the target transmits a short message to the tracker to indicate its actual location, moving speed, and bearing. The tracker, upon receiving the message, updates the target location and renews the prediction process according to the information stored in the short message. However, if the distance is less than the threshold, the target does not send a short message to the tracker. The tracker continues to use its predicted location information to mark the target location because the difference between the actual location and the predicted location is within the acceptable range.

### C. Dynamic Threshold

Threshold  $TH$  affects both the number of transmitted short messages and the location accuracy. A large threshold reduces the number of short messages as well as the location accuracy; (ie) there is a large difference between the predicted location and the actual location. By contrast, the small threshold requires relatively an increased

number of short messages; but, it increases the location tracking accuracy.

The user tolerance of the perceived location accuracy mainly depends on the moving speed. When the speed of the target is high, that is, while driving, the tracker can tolerate a higher location tracking inaccuracy. On the other hand, when the speed of the target is low, that is, while walking, the tracker requires a higher target location tracking accuracy. Therefore, a feasible mechanism is to dynamically adjust the threshold according to the current moving speed of the target. This solution satisfactorily maintains the number of transmitted short messages and the location tracking accuracy.

Thus, according to the moving speed of the target, the dynamic threshold can be set as  $TH = VC$ , where  $V$  is the current moving speed and  $C$  is a constant (e.g., 50 is used as the value of  $C$  in subsequent experiments).

## IV. DEVELOPED LBD SYSTEM

### A. System Architecture

The developed LBD system mainly comprises the tracker and target sides and is built on the GPS and Android application framework. The tracker side comprises the following components: SMS Switch, SMS Receiver, Predictor, and Offline Map. The operation procedure is as follows. The tracker first uses the SMS switch to deliver the "TraSMS;null;null;Q;Start Track;" message to inform the target that it should start transmitting its location.

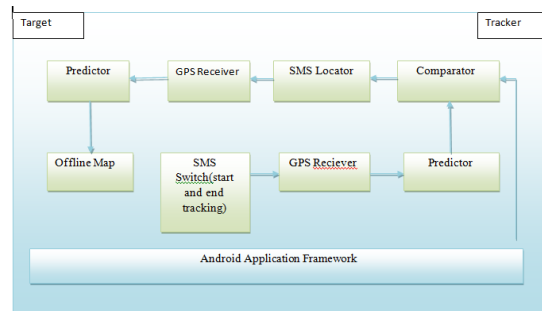

### System Architecture

The Offline Map periodically updates the target location information on the local tracker phone according to the predicted location information obtained from the Predictor. However, when the tracker receives a response message from the target,

it means that the accuracy of the predicted location is too low. Therefore, the Offline Map updates the target location information according to the received message rather than according to its prediction. The messages from the target are received by the SMS Receiver on the tracker side. The SMS Receiver extracts location information (e.g., coordinate, speed, and bearing) from the received message and passes it to the Offline Map, which in turn displays and marks the target location on a map. After completing the tracking action, the tracker uses the SMS Switch to transmit the “TraSMS;null;null;Q;End Track” message to inform the target to stop transmitting its location information.

Similarly, the target side comprises the following components: SMS Locator, SMS Receiver, Predictor, and Comparator. The operation procedure is as follows. When a start tracking message is received by the SMS Receiver, the target starts obtained by the GPS to verify whether the distance between the two exceeds the threshold. When the distance exceeds the threshold, the SMS Locator sends a response message to the tracker. The above procedure is performed iteratively until the track process is terminated. The GUI of a mobile phone is on the tracker side. The start tracking and stop tracking buttons, are pressed to start and stop tracking a moving object, respectively. The map view button is pressed to display the tracking information of the target on an offline map.

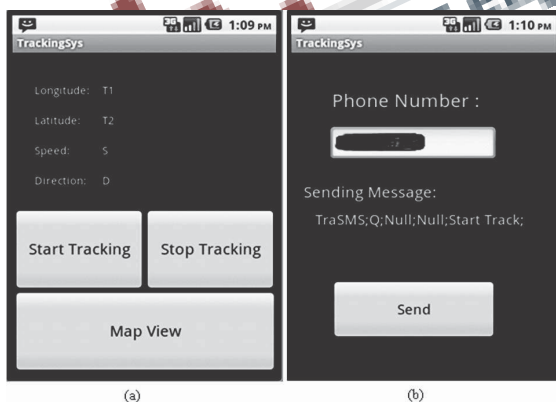

### B. Offline Map

Electronic maps are stored in the tracker’s mobile phone in advance to avoid a massive increase in

the transmission cost for obtaining the online maps. The SQLite database is embedded to save the map information in the mobile phone. SQLite is sufficient when the amount of processing data is small or when the data is only used by a single user. The SQLite database has many features in common with other public database systems, including the use of SQL-92 language syntax and atomic, consistent, isolated, and durable (ACID) transactions. The SQLite database is in the form of a single file, thereby avoiding a database system installation. Thus, it is quite simple to copy or create the database on a mobile device. A programming language is used to call the provided functions through the SQLite library.

We use the SQLite database as a single file to store and retrieve the map information. Furthermore, a program, called RMap, is installed for displaying the offline map on an Android mobile phone. The RMap uses the concept of overlays to draw the map and further marks the target’s location on the map on the basis of the information retrieved from the received short messages or from the predictor.

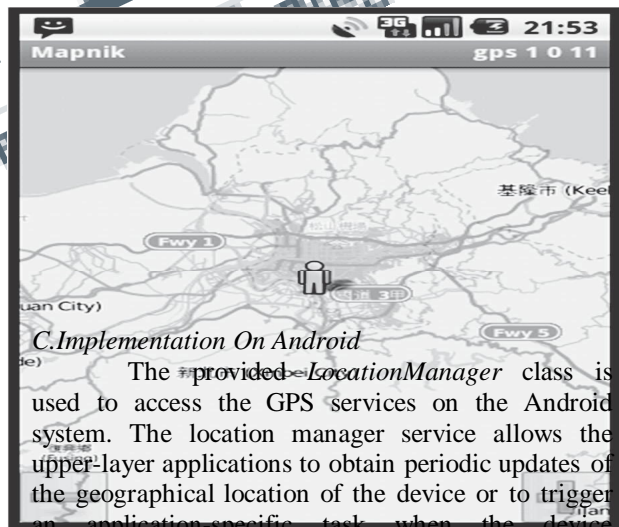

### C. Implementation On Android

The provided *LocationManager* class is used to access the GPS services on the Android system. The location manager service allows the upper-layer applications to obtain periodic updates of the geographical location of the device or to trigger an application specific task when the device approaches the determined geographical location. Continuous monitoring and updating of an object’s movement can be performed by using both *LocationUpdates* and *LocationListener*. Similarly, the provided *SmsManager* class is used to access SMS-related functions on an Android system, for example, by calling the *send- TextMessage* class to transmit a

short message. Android adopts a permission-based policy, indicating that the permissions required by an upper-layer application should be specified in the AndroidManifest.xml file in advance. Thus, before using *Sms-Manager*, the two permissions SEND SMS and RECEIVE SMS must be added to that file.

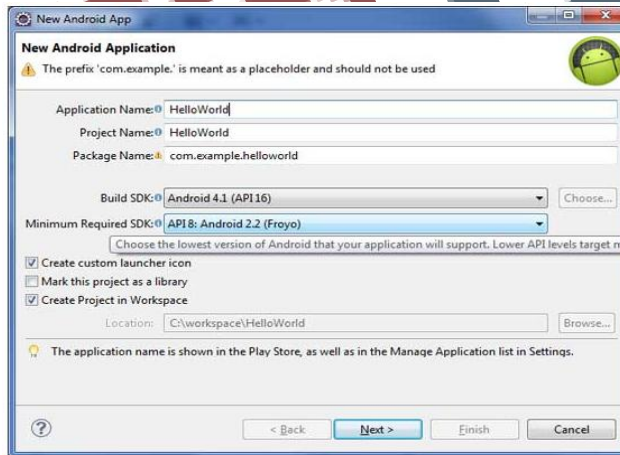
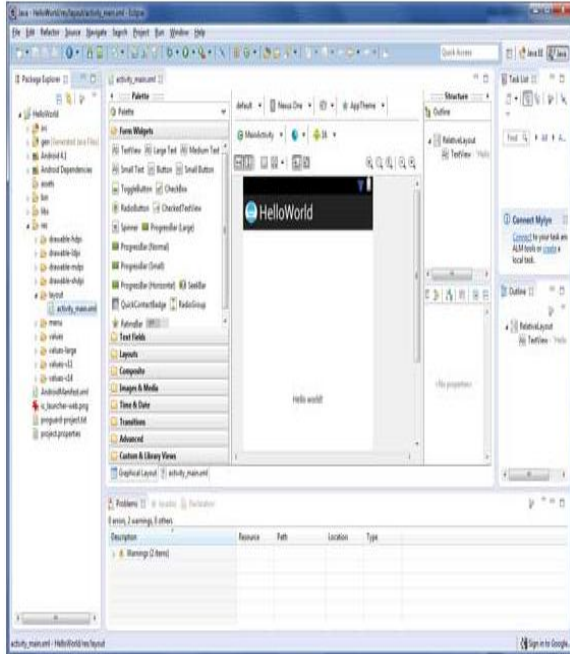

## V. CONCLUSIONS AND FUTURE WORKS

A handful of studies have developed location tracking applications through SMS. However, SMS is a user-pay service. The number of

SMS transmissions must be minimized while maintaining the location tracking accuracy within the acceptable range to reduce the transmission cost. This study proposes a novel solution, LBD, to this problem, and further develops a realistic system for tracking the target location. In addition to defining the short message format, LBD uses the current location, speed, and bearing of the target to predict its next location. In LBD, the moving pattern information of the target is transmitted only when the distance between the predicted location and the actual location exceeds a certain threshold, which is dynamically adjusted according to the speed of the target. The experiment shows that, in LBD, the number of short messages required is significantly reduced as compared with TBD and DBD. In addition, LBD achieves an acceptable location tracking accuracy. Finally, the use of a dynamic threshold reduces the required number of short message transmissions compared with the fixed threshold.

In this evaluation, we have assumed that a target moves erratically at low speed. Thus, the proposed LBD finds potential applications for elderly care and childcare. In addition, LBD is used in car monitoring and tracking applications because it works under the condition that the target moves at a high speed. However, further studies are required to verify these applications.

A notable limitation is that LBD can only track one target at a time. We extend this work for future studies on monitoring multiple targets simultaneously by taking into account additional value-added services.

## REFERENCES

1. Yuan-Cheng Lai, Jian-Wei Lin, Yi-Hsuan Yeh, Ching-Neng Lai, and Hui-chuan Weng "A Tracking system using Location Prediction And Dynamic Threshold For minimizing SMS Delivery" in *Journal Of communication & networks*, Feb 2013.
2. H. H. Lee, I. K. Park, and K. S. Hong, "Design and implementation of a mobile devices-based real-time location tracking," in *Proc. UBIKOMM*, 2008, pp. 178–183.
3. Z. Tian, J. Yang, and J. Zhang, "Location-based services applied to an electric wheelchair based on the GPS and GSM networks," in *Proc. ISA*, 2009, pp. 1–4.

4.I. Lita, I. B. Cioc, and D. A. Visan, "A new approach of automobiie iocai- ization system using GPS and GSM/GPRS transmission," in *Proc. ISSE,2006*, pp. 115–119.

5.S. A. Hameed, O. Khaiifa, M. Ershad, F. Zahudi, B. Sheyaa, and W.Asender, "Car monitoring, aiering, and tracking modei: Enhancement with mobiitiy and database faciitiies," in *Proc. ICCCE, 2010*, pp. 1–5.

6. R. E. Anderson, A. Poon, C. Lustig, W. Brunette, G. Borrieiio, and B. E. Koiko, "Buiiding a transportation information system using oniy GPS and basic SMS infrastructure," in *Proc. ICTD, 2009*, pp. 233–242.

7. W. J. Choi and S. Tekinay, "Location-based services for next-generation wireiess mobiie networks," in *Proc. IEEE VTC, 2003*, pp. 1988–1992.

8. R. E. Anderson, W. Brunette, E. Johnson, C. Lustig, A. Poon, C. Put- nam, O. Saiihbaeva, B. E. Koiko, and G. Borrieiio, "Experiences with a transportation information system that uses oniy GPS and SMS," in *Proc. ICTD, 2010*.

9.A. Civiis, C. S. Jensen, and S. Pakainis, "Techniques for efficient road- network-based tracking of moving objects," *IEEE Trans. Knowl. Data Eng.*, voi. 17, no. 5, pp. 698–712, 2005.

10.M. Zahaby, P. Gaonjur, and S. Farajian, "Location tracking in GPS usingKaiman fiiter through SMS," in *Proc. IEEE EUROCON, 2009*, pp. 1707–1711.

11.P. Perugu, "An innovative method using GPS tracking, WINS technoio- gies for border security and tracking of vehicies," in *Proc. RSTSCC, 2010*, pp. 130–133.

