

Development of Effective Docking For Autonomous Mobile Robot

^[1] M V Sreenivas Rao, ^[2] Dr. M. Shivakumar

^[1] Associate Professor, Dept. of IT ^[2] Professor and Head, Dept. of IT
^{[1][2]} GSSS Institute of Engineering & Technology for Women, Mysore

Abstract-- Docking and recharging system for a autonomous mobile robot must guarantee the ability to perform its tasks continuously without human intervention. In this work we present a system for autonomous recharge of the batteries of Fire Bird V robot. To find the presence of an obstacle sharp sensors and IR Proximity sensors are used. To follow the path Fire Bird V robot use black line sensors. The robot uses black line follower path on a white surface. To monitor the battery voltage level, battery sensor which is already present in ATmega 2560 is used. It senses the line and monitor the robot to stay on path, while constantly correcting wrong moves. On the way to its destination if it finds any obstacle ,the sharp sensor or the IR proximity sensor will sense the obstacle and make the beep sound. When there is no obstacle the robot continues its journey. During its journey if its battery gets drained below the threshold value , then it has to go to the nearby power station and charge the battery with the help of wireless power transmission module the robot charges itself.

Index Terms—Infrared Proximity sensor (IR sensor), Fire Bird V, Charge Couple device(CCD)

I. INTRODUCTION

In industries these days, robots are commonly used in the workspace, it is a challenge to the developer to make robots human friendly and less hazardous and also eco-friendly. And the robot must be developed in such a way that any ambiguity, the robot itself corrects it. In this work, the robot follows the path and avoids the obstacle in its way along with monitoring its battery voltage level which is one of the most important and task. Robot can move in straight, and curved paths and it indicates the presence of an obstacle through voiced mode i.e. it beeps whenever there is a presence of an obstacle in the path. when the charge of the robot is less than the threshold value then it gives a visual indication by displaying “charge” on display. Along with monitoring the battery level, whenever the battery is low then the robot goes towards the nearby station by detection the node and goes to the station and stops. And in the station it charges the battery with the help of wireless power transmission module. In this project we deal with fire bird V in order to avoid obstacle and also to monitor battery using atmega2560. Here we use 2 types of microcontroller that is ATMEGA2560 as Master microcontroller and ATMEGA8 as Slave microcontroller. Battery monitoring is one of the most important parameter which must be supervised regularly in industries.

II PROPOSED METHODOLOGY

The black line sensors, sharp sensors, IR proximity sensors and battery monitoring sensors are present in the Fire Bird V kit. It has a microcontroller that is ATMEGA2560 as Master microcontroller and it consists of 3 line sensors, 5 Sharp sensors, 8 IR Proximity sensors and battery voltage sensor. It also has LCD, Buzzer and indicator LED's. It also has 2 DC geared motors in differential drive configuration and a caster wheel at front of the robot for support.

The line sensors are present beneath the microcontroller kit. It detects the line and thus follows the path. Along with this the IR proximity sensors are also used. These IR sensors have a receiver and a transmitter. It transmits the light and based on how much light is reflected back it gives the presence of the line or object. The results of this is analog in nature therefore the result is required to be converted into binary form so that the system/robot can understand to perform the tasks based on the results from the sensor. To convert the analog to digital form we make use of ADC which is present in the ATMEGA 2560 microcontroller kit. It is present as MUX. ADC is from pin no 82. There are 5 sharp sensors present in the Fire Bird V kit. Sharp sensors are used in the detection of an obstacle in the workspace or in the path of the robot. Sharp sensors works on principle of angle i. e this sensor also has a transmitter and a CCD array[1]. The rays from the

International Journal of Engineering Research in Computer Science and Engineering (IJERCSE)
Vol 3, Issue 5, May 2016

transmitter hits the obstacle and reflects back to the CCD array with a certain angle and from this the distance of the object can be calculated. The result is analog in nature and therefore it also must be converted into binary for the robot to understand and perform necessary action. For battery monitoring we use the inbuilt ports and pins available in the Fire Bird V kit. Block diagram of Fire Bird V robot is shown in the Fig 1.

It consists of line sensor, Sharp sensor, IR proximity sensor, LCD display, ATMEGA 2560 microcontroller, Battery voltage sensor [2], Buzzer and Motion control device.

A. Sharp Sensor

Sharp sensors are used for accurate distance measurement. It consists of IR LED and CCD array. IR LED transmits a narrow IR beam, then the reflected angle is measured using the CCD array to estimate distance from the obstacle[3]. When this sensor senses any obstacle, then the robot stops.

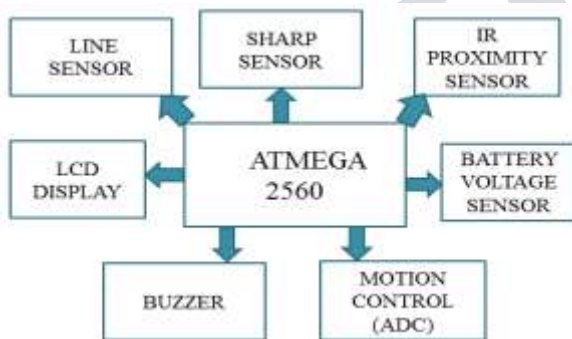

Fig 1: Block diagram of Fire Bird V robot.

B. Line sensor

Line sensors are used to give robot a sense of localization, i.e the path it has to follow. It consists of a highly directional photo transistor for line sensing and bright red LED for illumination. When the sensor is on a black line, no light gets reflected therefore resulting in considerable decrease in the leakage current[5]. Hence it moves along the path. During turnings whenever the line sensors go on the white surface then it has to make corresponding error correction so that the line sensor comes back on to the line and continue its journey. Power to the red LEDs of line sensor is controlled by PG5 of ATMEGA2560 microcontroller.

C. Infrared Proximity Sensors

IR proximity sensors are used to detect proximity of any obstacles in the short range. IR proximity sensors have about 10cm sensing range. These sensors sense the presence of obstacles in the blind spot region of sharp IR range sensor. Fire Bird V robot has 8 IR proximity sensors. When an object is close to the sensor, the light from the LED bounces off the object and into the light sensor. This results in a large jump in the intensity, In the absence of the obstacle there is no reflected light hence no leakage current will flow through the photo diode and output voltage of the photo diode will be around 3.3V. As obstacle comes closer, more light gets reflected and falls on the photo diode and leakage current flowing through the photo diode starts to increase which causes voltage across the diode to fall[8]. And thus taking this as a indication it is given to the robot as obstacle and thus the robot stops.

D. Motion Control

Fire Bird V robot has two 75 RPM DC geared motors in differential drive configuration along with the third caster wheel for the support. Robot has top speed of about 24cm per second. Using this configuration, the robot can turn with zero turning radius by rotating one wheel in clockwise direction and other in counter clockwise direction. Port A is used for motion control. Motion control involves velocity and direction control. To change the direction of the motor, appropriate logic levels (High/Low) are applied direction control pins. Velocity control is done using Pulse Width Modulation (PWM)[10].

1. Direction Control:

Motors are controlled by L293D dual motor driver which can provide up to 600mA of current to each motor. To change the direction of the motor, appropriate logic levels (High/Low) are applied to the direction control pins.

Table 1: Direction Control

DIRECTION	PA3(RB)	PA2(RF)	PA1(LF)	PA0(LB)
FORWARD	0	1	1	0
BACKWARD	1	0	0	1
LEFT	0	1	0	1
RIGHT	1	0	1	0
SOFT LEFT	0	1	0	0
SOFT RIGHT	0	0	1	0
STOP	0	0	0	0

2. Velocity Control:

Port L is used for velocity control (i.e. Pin no 3 & 4). Velocity control is done using pulse width modulation. Pulse width modulation is a process in which duty cycle of constant frequency square wave is modulated to control power delivered to the load i.e. motor. Duty cycle is the ratio of 'TON/ T'. Where 'TON' is ON time and 'T' is the time period of the wave. Power delivered to the motor is proportional to the 'TON' time of the signal. In case of PWM the motor reacts to the time average of the signal. PWM is used to control total amount of power delivered to the load without power losses which generally occur in resistive methods of power control.

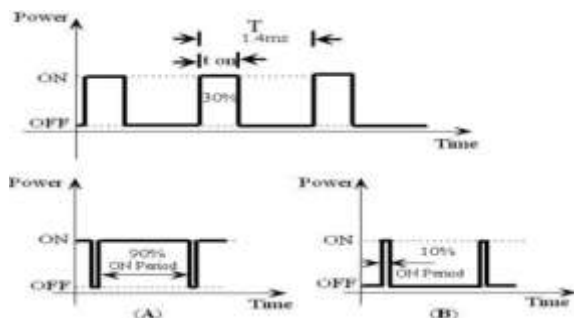

Fig 2: Pulse Width Modulation (PWM)

As shown in Fig 2, In case (A), ON time is 90% of time period. This wave has more average value and hence more power is delivered to the motor. In case (B), the motor will run slower, as the ON time is just 10% of time period.

E. LCD Display

HD44780 IC is used in order to display the contents. Port c handles both buzzer and LCD. Leaving port c3 rest all are given to LCD display. LCD interfaced in 8 or 4 bit modes. In 8 bit mode which requires 3 control line and 8 data lines. Fire bird v robot uses 4 bit interfacing mode which requires 3 control lines and 4 data lines. In this mode upper and lower nibble of the data/command needs to be sent separately.

F. Buzzer

Robot has 3 KHz piezo buzzer. It can be used for debugging purpose or as attention seeker for a particular event. The buzzer is connected to PC3 pin of the microcontroller. Also the same buzzer is used in battery monitoring circuit to alert the battery low indication.

G. Battery Voltage Sensor

Fire Bird V is powered by 9.6V rechargeable Nickel Metal Hydride battery pack. The battery voltage can vary between 12V (fully charged) to 8V (discharged). Here the battery voltage sensor acts as a voltmeter and sets the threshold voltage. During the process, if the charged voltage decreases below threshold value then robot comes back to the nearest station. The robot comes to either source or destination, gets charged and continues in its desired path.

H. Wireless Power Transmitter

Power is given to the oscillator circuit which supplies Direct current (DC) which is converted into high frequency Alternating Current (AC) into the transmitter. The alternating current energizes a copper wire coil in the transmitter, which generates a magnetic field. The receiver section consists of receiver coil, rectifier circuit and a voltage regulator IC. The AC current flowing through the transmitter coil creates a magnetic field. When we place the receiver coil with in a specific distance from this transmitter coil, the magnetic field in the transmitter coil extends to this receiver coil, and it induces an AC voltage and generates a current flow in the receiver coil of the wireless charger[13]. At the end receiving device then converts the alternating current back into direct current, which becomes usable power. The Fig 3 shows block diagram of wireless power transmission circuit and its main components required.

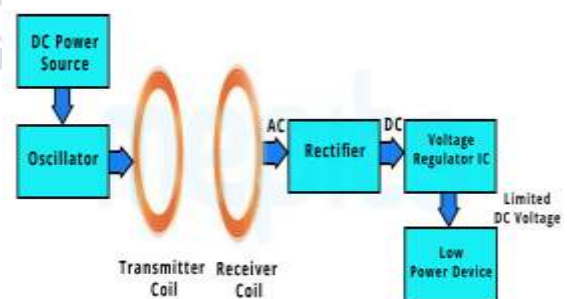

Fig 3: Block diagram of wireless power transmission circuit

III RESULTS

The output of this system is that a robot which can follow the line from source to destination by avoiding all the obstacles which come across its path and along with that it also monitors the battery of the robot so that it can avoid

International Journal of Engineering Research in Computer Science and Engineering (IJERCSE)
Vol 3, Issue 5, May 2016

sudden shut down due to loss of charge. This helps in the industry where robots are widely used.

The robot follows the black line on the white background and follows the line, which forms the line follower robot. When any obstacle comes in the path of the robot then the robot stops and then the buzzer is on until the obstacle is removed from the path and then continues its journey. On its way if the battery voltage drops below the threshold value then the robot goes towards the nearest node which has the path to the charging station. When the robot gets docked in charging station, there with the help of the power transmission module the battery of robot is charged. Fig 4: Robot in the charge station



Fig 4: Robot in the charge station



Fig 5: Robot with the Power transmission module in the charge station



Fig 6: Overall Project Setup

IV CONCLUSION

We have developed a obstacle avoidance and low battery indication algorithm which is efficient to perform the task. Our robot uses different sensors to detect path and obstacle, and also LCD to display. For working of all these sensors and to display we have written codes in embedded C. Dump the code to fire bird V using boot loader, on those instruction robot travels from source to destination by detecting obstacle and by monitor the battery.

REFERENCES

- [1] T.Amulya,M.Vedachary and P. Srilaxmi "Implementation of Surveillance robot with the feature of semi automatic recharging capability" International Journal Of Engineering And Computer Science ISSN: 2319-7242 Vol 4 No10, Oct 2015.
- [2] Gurrapu Seshadri and M.Kishore Babu "Best Battery Charging Using a Solar Energy for Robotic Vehicle Based on Relay-Host Microcontroller", International Journal of Emerging Trends in Engineering Research (IJETER), Vol. 3 No.6, 2015.
- [3] Lok Prasad Khanal "OBSTACLE-AVOIDING ROBOT" Bachelor's Thesis abstract Turku University of applied sciences, 50 December, 2013
- [4] Paul Kinsky, Quan Zhou "Obstacle Avoidance Robot" WORCESTER POLYTECHNIC INSTITUTE , The Degree of Bachelor of Science, Date: Aug-2011
- [5] Stephen Whitely 'Battery management, power supply and safety systems in an electric drive vehicle'

International Journal of Engineering Research in Computer Science and Engineering (IJERCSE)
Vol 3, Issue 5, May 2016

- 10119492 School of Mechanical Engineering,
University of Western Australia 3rd November 2008
- [6] Sejal Jaiswal 'Obstacle detection and avoidance by a mobile robot' 110CS0442 Department of Computer Science and Engineering National Institute of Technology Rourkela, Rourkela-769008, Odessa, India , May 2013
- [7] Lok Prasad Khanal "OBSTACLE-AVOIDING ROBOT" Bachelor's Thesis abstract Turku University of applied sciences, 50 December, 2013
- [8] Andreas Birk, 'Autonomous recharging of mobile robot 'AI-lab, Vrije University Brussel Belgium Draft Version (paper # 97RO029) accepted at ISATA '97, Florence, 1997
- [9] J.Borenstein " Real-time obstacle avoidance for fast mobile robots" Adv. Technol. Lab, Michigan Univ, Ann Arbor, MI, USA , [IEEE Transactions on Systems,Man,Cybernetics](#) (Volume:19, [Issue:5](#))Sept .-Oct.1989
- [10] Cosmin Codrea, Thomas Hirth , "Measurement of Battery Capacity in Mobile Robot Systems" Fraunhofer IIS Am Wolfsmantel 33, 91058 Erlangen, Germany , Dept. of Computer Science , University of Erlangen-Nuremberg Martensstr. 3, 91058 Erlangen, Germany.
- [11] [J. Borenstein](#) "Obstacle avoidance with ultrasonic sensors" Dept. of Mech. Eng. & Appl. Math, Michigan Univ , Ann Arbor, MI, USA , [IEEE Journal on Robotics and Automation](#) (Volume:4 , [Issue: 2](#)) April 1988
- [12] Andreas Birk, 'Autonomous recharging of mobile robot 'AI-lab, Vrije University Brussel Belgium Draft Version (paper # 97RO029) accepted at ISATA '97, Florence, 1997
- [13] Lakshya K Ankolekar and M.V. Chidananda Murthy 'Autonomous navigation mobile robotic system' International Journal of Emerging Technology in Computer Science & Electronics (IJETCSE) ISSN: 0976-1353 Volume 14 Issue 2 –APRIL 2015
- [14] Gurrapu Seshadri and M.Kishore Babu "Best Battery Charging Using a Solar Energy for Robotic Vehicle Based on Relay-Host Microcontroller", International Journal of Emerging Trends in Engineering Research (IJETER), Vol. 3 No.6, 2015
- [15] Cosmin Codrea, Thomas Hirth , "Measurement of Battery Capacity in Mobile Robot Systems" Fraunhofer IIS Am Wolfsmantel 33, 91058 Erlangen, Germany , Dept. of Computer Science , University of Erlangen-Nuremberg Martensstr. 3, 91058 Erlangen, Germany.