

ANALYSIS OF SMI,LSMI,KALMAN BASED LMS AND KALMAN BASED RLS FOR ADAPTIVE BEAMFORMING

^[1] G.Essakki Priyanka, ^[2]C.Gayathri
^[3]Nazneen Ansari Dr.G.Indumathi Prof./ECE

^{[1][2]} Dept. of Electronics And Communication Engineering, Mepco Schlenk Engineering College, Sivakasi,Tamilnadu
ge.priyanka94@gmail.com,cskgayumay27@gmail.com,

^[3] . of Electronics And Communication Engineering, Mepco Schlenk Engineering College, Sivakasi, Tamilnadu
gindhu@mepcoeng.ac.in

Abstract: – when the array steering vector is known then in adaptive beam forming we can have resolution and interference rejection capability. In this paper we propose a variety of approaches like SMILSMI,Kalman based LMS and Kalman based RLS for adaptive beamforming through simulation result various adaptive beamforming algorithm can be analysed.

Index Terms— adaptive array,adaptive beam forming, SMILSMI,Kalman based LMS and RLS.

I. INTRODUCTION

In recent times due to globalization the need for wireless communication is the most important criteria .It is based upon the necessity to enhance the coverage area, quality of signal. The existing antenna architecture the weight of the antenna arrays are processed and changed rapidly to direct the main beam in the desired direction and nullify the interfering signal. A variety of approaches like SMI, LSMI, and KALMAN based LMS and KALMAN based RLS to adopt the weights in smart antenna systems. These can provide higher coverage, higher bit rate, increase signal to noise ratio, higher system capacities, Mobility, spectral efficiency, Improved link quality, reduce multipath and co-channel interference. With correct selection of μ value the method converges the weight quickly in LMS.

II. MATHEMATICAL MODEL

A smart antenna system consists of a number of antenna elements which are arranged in different categories (linear, circular etc) and whose weights are adjusted with smart signal processing algorithms which is used to identify the direction of arrival (DOA) of the signal and can be used to calculate beamforming vectors.As shown in Fig.1 both

desired and undesired signals reach antenna elements and adaptive algorithm processes the weights to get the desired signal.

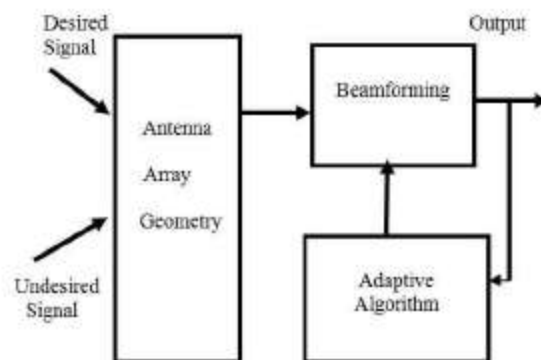

Fig.1 Block diagram of Smart antenna system

III. THEORETICAL MODEL FOR SMART ANTENNA SYSTEM

The smart antenna system can be categorized into three parts. It is clearly depicted in Fig 2.

1. The first one performs the direction of arrival of the signal (DOA) estimation and determines the received input data through number of incoming wave fronts.
2. The second one performs the DOA classification. It finds which wave fronts are from original user and which ones are from the interferers.
3. The third one is the beam forming algorithm. It forms an antenna array pattern with a main beam steered in the direction of the desired user, while minimizing the impact of the interfering wave fronts and the noise.

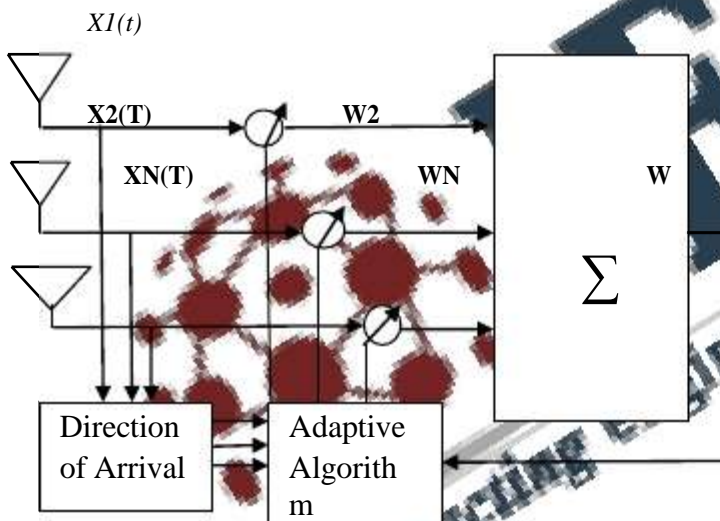

Fig.2 Theoretical model for smart antenna system

IV. PROBLEM FORMULATION

Consider a linear array (LA) with

M omnidirectional antenna elements spaced by the distance d impinging from directions $\{\theta\}$. The observation vector is given by

$$X(k) = S(k) + i(k) + n(k) \\ = S_0(k)a + i(k) + n(k)$$

Where

$X(k) = [x_1(k), x_2(k), \dots, x_M(k)]^T$ is the complex vector of array observation

$S_0(k)$ is the signal wave form

a is the signal steering vector

$i(k)$ and $n(k)$ are the interference and noise component

For the array shown in Fig.3, the array factor, for a linear array of N elements with an inter-element spacing d , is given by [5]:

$$AF(\theta) = \sum_{n=0}^{N-1} \omega_n e^{jnkd \cos(\theta)}$$

Where

ω_n = complex array weight at element n ,

θ = angle of incidence of electromagnetic waves wave from array axis,

k = wave number ($2\pi/\lambda$), and

λ = wavelength.

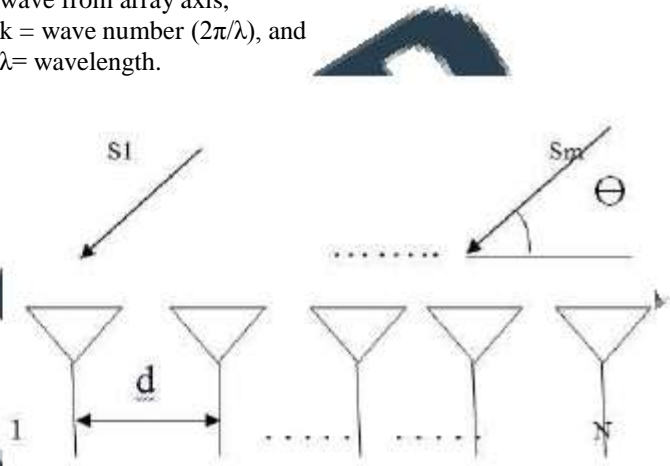

Fig.3. Linear array geometry

V. DIFFERENT BEAMFORMING ALGORITHM

Adaptive beam forming is a technique in which antenna elements are exploited to achieve maximum reception in a specified direction by estimating the desired direction while signals of the same frequency from other directions are rejected. It is achieved by varying the weights of each of the sensors used in the array. This allows the antenna system to focus the maxima of the antenna pattern towards the desired mobile while minimizing the impact of interference and other effects from undesired mobiles [4].

The present paper describes about simulated adaptive beam former KLMS, SMI and LSMI method. The output of the array is the weighted sum of the received signals at the array elements and the noise at the receivers connected to each element. The weights iteratively computed based on the array output and a reference signal that approximates the desired signal and previous weights. Reference signal is approximated to the desired signal. An adaptive algorithm will minimize the error between a desired signal and array output [4].

KLMS technique

The LMS Algorithm is the most acceptable form of beamforming algorithm, being used in several communication applications. The LMS Algorithm adapts the weight vector along the direction of the estimated gradient based on the steepest descent method [3]. The weight vector updating for LMS Algorithm is given by

$$W(n+1) = w(n) + \mu x^*(n)e(n) \\ e(n) = d(n) - x(n)w(n)$$

The Kalman filter is an algorithm which uses a series of measurements observed over time, containing noise

(random variations), and produces estimates of unknown variables that tend to be more precise than those that would be based on a single measurement alone. The Kalman filter operates recursively on streams of noisy input data to produce a statistically optimal estimate of the underlying system state [5]. The Kalman based LMS algorithm is less sensitive to the measurement noise. It also ensures fast convergence, high accuracy in the weight estimate, stability and decreased computational complexity.

The algorithm works in a two-step process: in the prediction step, the Kalman filter produces estimates of the current state variables, along with their uncertainties. Once the outcome of the next measurement is observed, these estimates are updated using a weighted average, with more weight being given to estimates with higher certainty. Because of the algorithm's recursive nature, it can run in real time using only the present input measurements and the previously calculated state [5].

The weight update equation of the kalman based normalized Least Mean Square (KLMS):

$$W(n+1) = w(n) + x(n)e(n) / (S(n) + (qv/\sigma^2 w(n)))$$

$$S(n) = x^T(n)x(n)$$

B. KRLS TECHNIQUE

The convergence speed of the LMS algorithm depends on the Eigen values of the array correlation matrix. An array correlation matrix with large Eigen value spread the algorithm converges with a slow speed. RLS requires reference signal and correlation matrix information.

An important feature of the recursive least square algorithm is that its convergence rate is faster than the LMS algorithm. This problem is solved with the RLS algorithm by replacing the gradient step size with a gain matrix at nth iteration, producing weight update equation

The RLS algorithm updating weight vector is given by

$$W(n) = w(n-1) + R^{-1}(n) e(n)$$

Where error is given by

$$e(n) = d(n) - X^T(n)w^*(n-1)$$

$R^{-1}(n)$ is the autocorrelation matrix of the signal

$$R^{-1}(n) = R^{-1}(n-1) - \frac{R^{-1}(n-1)x(n)x^T(n)}{1 + x^T(n)R^{-1}(n-1)x(n)}$$

Kalman based normalized Recursive Least Square (KRLS) algorithm is an adaptive beam forming algorithm. The optimal weight value is obtained by means of iterative operation according to the rule of MMSE (minimum mean square error). Adaptive algorithm computes the output based on received signal and weight vector. The weight vector is adjusted based on the error between output and expected signal. The above progress is continuing iterative operation

course until it satisfies the demand and comes into the steady state.

Kalman based recursive least square algorithm weight update equation is given by

$$W(n) = w(n-1) + \frac{R^{-1}(n) e(n)}{(S(n) + (qv/\sigma^2 w(n)))}$$

$\sigma^2 w(n)$ = variance of weight

qv is the auto correlation function of the state noise

C. SMI (Sample Matrix Inversion) Algorithm

The Sample matrix inversion is also called as Direct Matrix Inversion Algorithm. Sample matrix is a Time average estimate of the array correlation matrix using k-time samples. If the random process is ergodic in the correlation, the time average estimate will equal the actual correlation matrix. [3]

$$\hat{R} = 1/N \sum_{i=1}^N X(i)X^H(i)$$

SMI weight vector can be written in the following form

$$W_{SMI} = \alpha \hat{R}^{-1} a$$

$$\alpha = a^H \hat{R}^{-1} a$$

D. Loaded Sample Matrix Inversion

The loaded SMI algorithm improves the disorder of the SMI against an arbitrary spatial by means of diagonal loading of the sample covariance matrix.

$$\hat{R}_{dl} = \hat{R} + \xi I$$

Where ξ is a diagonal loading factor. So that, we can write the LSMI weight vector in the following form

$$W_{LSMI} = \hat{R}_{dl}^{-1} a = (\hat{R} + \xi I)^{-1} a$$

Although LSMI algorithm can improve the performance of SMI algorithm in scenarios with an arbitrary steering vector mismatch, this improvement is not significant because LSMI algorithm exploits the presumed steering vector and therefore its performance degrades when the norm of the error vector is large. Furthermore the optimal choice of the parameter ξ depends on the unknown signal and interference parameters and therefore the proper choice of ξ represents a serious problem in practical applications.

V. SIMULATION RESULTS

A. Analysis of Kalman Based Normalized Least Mean Square (KLMS) algorithm.

Here 6 antenna elements are used in linear array. These elements are identical (antenna array made up of all the same type of antennas), and have the same physical orientation (all point or face the same direction).

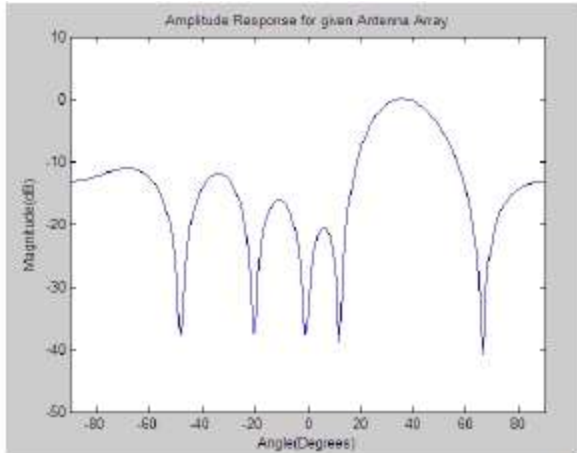
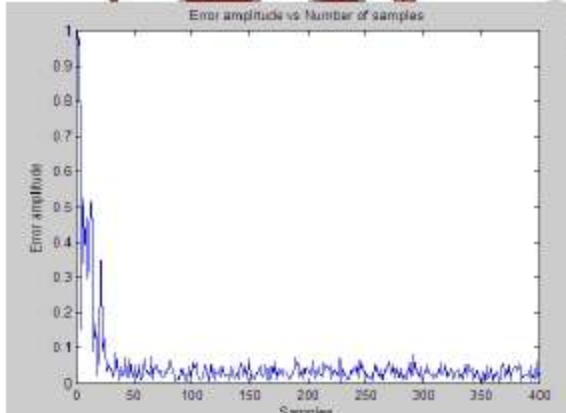

Fig.4 Angle of Arrival Vs Amplitude response: Beam steered at 35° (Signal of interest) and interferer null at -20° and 0° using KLMS algorithm

It is considered that the desired user is arriving at an angle 35° and an interferer at an angle -20° and 0°. Amplitude responses is computed for 6 elements and the Fig 4. shows the amplitude response and how the KLMS algorithm places deep nulls in the direction of interfering signals and maximum in the direction of the desired signal. Fig 5. shows Magnitude of error vs. number of samples for KLMS algorithm



B..Analysis Of Smi Algorithm

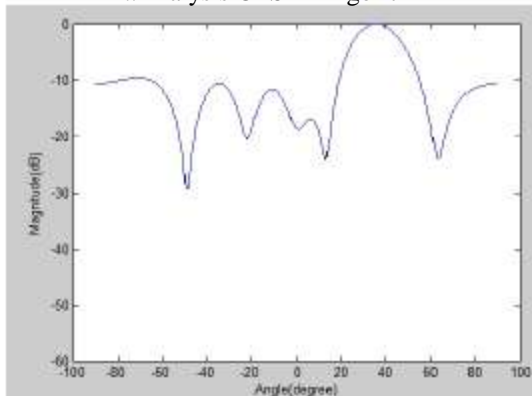

Fig.6 angle of arrival vs amplitude response: beam steered at 35° (signal of interest) and interferer null at -20° and 0° using smi algorithm
 amplitude responses is computed for 6 elements and the fig 6. Shows the amplitude response and how the smi algorithm places deep nulls in the direction of interfering signals and maximum in the direction of the desired signal.

C..analysis of lsmi algorithm

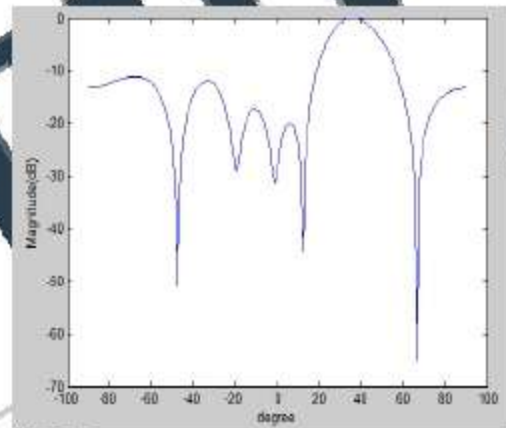

Fig.7 Angle of Arrival Vs Amplitude response: Beam steered at 35° (Signal of interest) and interferer null at -20° and 0° using LSMI algorithm

Amplitude responses is computed for 6 elements and the Fig 7. shows the amplitude response and how the LSMI algorithm places deep nulls in the direction of interfering signals and maximum in the direction of the desired signal.

D.Comparison of the beam patterns

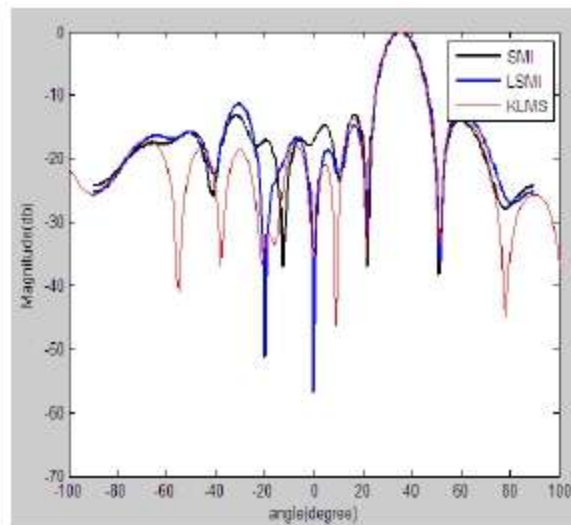

Fig 8 shows the comparison of the different beamforming algorithms

VI. CONCLUSION

In this paper adaptive beam forming algorithm using Kalman based LMS, Kalman based RLS, SMI and LSMI are proposed. These algorithms are used to adapt the weights of the array, realizing the desired parameters (i.e., main beam steering, deep null placement in the undesired signal direction, etc.) under noise environment. From the simulation results it can be inferred that KLMS places deeper nulls in the direction of undesired signals. In future several other algorithms can be used for beamforming

References

- P. Akhtar , M. Yasin , Performance Analysis of Bessel Beamformer and LMS Algorithm for Smart Antenna Array in Mobile Communication system SpringerVerlag Berlin Heidelberg ,IMTIC 2012, CCIS 281, 2012, pp. 5261.
- Xin Song, Jinkuan Wang, Xuefen Niu, -Robust adaptive beamforming algorithm based on neural network Automation and Logistics, 2008, ICAL 2008, IEEE International Conference, pp.1844 - 1849
- L. Surendra, Syed Shameem, Dr. Habibullah Khan, Performance Comparison of LMS, SMI and RLS Adaptive Beamforming Algorithms for Smart Antennas, ICST Vol. 3, Issue 2, April - June 2012.
- [4] Ch. Santhi Rani, Dr. P. V. Subbaiah, Dr. K. Chennakesava Reddy, -LMS and RLS Algorithms for Smart antennas in a CDMA Mobile Communication environment, International Journal of the Computer, the Internet and Management, Vol.16, No.3, 2008, pp. 12-21.
- [5] C.A. Balanis, Antenna Theory Analysis and Design, Wiley- India 2nd edition, 2007.