

# RFID Based Automatic Vehicle Identification for Access Control

<sup>[1]</sup>Shubham Swaraj, <sup>[2]</sup> Assistant Prof. Richa R Khandelwal  
<sup>[1][2]</sup>Department of Electronics Engineering,  
Shri Ramdeobaba College of Engineering and Management,  
Rashtrasant Tukadoji Maharaj Nagpur University.  
Nagpur, Maharashtra, India..

---

**Abstract:** - There has been rising interest for secure framework that should be tried and true and fast react for the commercial enterprises and organization. RFID (Radio Frequency Identification) is one of the reliable and quick method for recognize the material article. In the long-prior the standardized tags are best when contrasted with RFID due to their expense however now a day's RFID are effortlessly accessible and are more helpful to utilize. Research has rolled out some extraordinary improvements which make its programming a great deal shorter and less demanding is a result of supplanting microcontroller with Arduino. Arduino makes the circuit and programming a considerable measure simpler to get it. Paper is based upon security get to and Control framework utilizing RFID and Arduino with GSM module. A percentage of the sensors are utilized like PIR, LPG for Leakage recognition. Security access framework is exceptionally helpful to use at home, office and business structures.

**Keywords-** Keywords: EM-18 Reader Module, RFID tags, Arduino UNO board.

---

## I. INTRODUCTION

Presently days there is a tremendous surge in the toll courts keeping in mind the end goal to pay the toll charge. Accordingly keeping in mind the end goal to lessen the congested road and to spare time and additionally to decrease the cash loss of 300 centers/year. Electronic/mechanized toll gathering frameworks are exceptionally well known nowadays. They don't require manual accumulation and operation of toll hindrances. The insights about the vehicles and installment are put away in a RFID based framework. We have composed venture for the robotization in toll charge installment utilizing RFID. We have made the computerization of toll square utilizing mix of microcontroller, RFID and Load cell innovation. This report clarifies the implantation of mechanization in toll court which is a stage towards enhancing the observing of vehicles, going in foreordain courses. The point of our undertaking is to outline a framework, which naturally recognizes a drawing closer vehicles and record vehicles number and time. In the event that the vehicle has a place with the approved individual, it naturally opens the toll entryway and a foreordained sum is consequently deducted from its record. This means lessened Traffic clog at toll courts and aides in lower fuel utilization. This is vital favorable position of this framework. Low recurrence RFID work at 125 KHz recurrence with radio waves. There is a loop inside the RFID tag and when it is affected by an

attractive field, it sends a 12 byte character code to RFID peruser for further preparing. The RFID tag is utilized as a special personality for record of a specific client. At the point when a vehicle drives through the toll square, its driver is provoked to output his RFID tag. On the off chance that the character (serial number of the tag, i.e., 12 byte information) is coordinated with the one as of now put away in the framework, the toll sum is deducted from his record. After this, the vehicle gets quick access to drive through. This RFID based toll framework likewise has some extra components. Another client can enlist him with the framework.

Additionally an old client can energize his record equalization. The sum for revive can be entered in the framework through a numeric keypad interfaced with AT89C51. In starting, the client is provoked to sweep his tag or ID. The serial code of the tag is distinguished by the peruser module and is sent to AT89C51 for correlation with put away information. On the off chance that the ID is coordinated by the microcontroller, the toll sum (for this situation Rs.10) is deducted from client's equalization and client gets the opportunity to drive through the square. In actuality, if the tag is not recognized, a message ('Wrong ID') is shown on LCD screen. Another client needs to press the "\*" switch to enlist himself after which his personality is confirmed with RFID tag. The new record is then put away by the microcontroller to allow future access. The framework likewise appears "Blunder" if the labels don't coordinate amid check. On the off chance that adjust in client's record turns out to be under Rs.30, a notice message

'Low adjust' is shown on LCD. For this situation the client still gets the entrance through the framework. The framework likewise prompts the driver to revive the record. In the event that adjust comes to beneath Rs.10, 'Deficient equalization' is demonstrated on LCD screen. The client does not get access until he adds more adjust to his record. The revive sum is entered by utilizing a keypad. Delete can be utilized while pressing so as to enter the sum "\*" catch on keypad. It additionally has a wellbeing highlight that if distinctive labels are looked over the peruser at the season of enlistment, LCD shows 'you have indicated diverse ID. At the point when a RFID label comes in this range, the peruser distinguishes it and sends a novel code of the tag serially. This serial code, comprising of 12 bytes, is gotten by the microcontroller. This code is the ID for the client and is put away as an exhibit in the microcontroller. In the event that the ID is coordinated with this code put away in exhibit of microcontroller, the client is conceded get to however the toll court.

## II. MOTIVATION

As of late we have seen the quantity of vehicle burglary and robbery vehicle offering have expanded far radically. In spite of the fact that some are at long last followed, numerous are never found. Vehicle securities have turned into an imperative issue in our nation. At the point when these vehicles are stolen then the numerous individuals bear an immense misfortune. Similarly at the toll square a considerable measure of time is spent to finish entire process. Sometimes we should be in a long line and after much time the procedure gets completed. So to spare time and things simple this thought rings a bell.

## III. RELATED WORK

Many researchers have utilized RFID technology in developing access control system. Filipe [7] has developed an RFID based monitoring and access control system consisting of RFID terminal, camera, server and an alert device. Upon detecting a transponder, the terminal captures a photo and transmits the data including the UID and photo to the server through TCP/IP connection. The server searches the database for this particular query and sends the results back to the terminal to allow or deny the access. The system also monitors illicit acts e.g., a person tries to enter when the door is open without completion of authentication process and turns on the alert device using web services. The performance of the system is tested by installing RFID kits with antennas covering a range of 10cm and satisfactory results are obtained. Xiang-Lei Meng [9] has described an RFID based embedded security authentication system with novel face recognition structure. The system comprises of two phases namely registration and recognition. In registration phase, ten pictures of user face with different

emotions are collected and eigen information is obtained with an extraction algorithm. This information along with a UID is written on RFID tag. In recognition phase, a camera tracks the face and an extraction algorithm returns eigen information of the face in the picture. This information is then matched with the information already stored on the tag for authentication. The entire processing is done on embedded ARM11 processor, S3C6410 instead of computer terminal/server which has resulted in faster response time, about 57ms with authentication accuracy up to 86.5%. The performance of the system is compared with the existing database systems and is found to have far better response time with the same authentication accuracy. Dong-Liang Wu [10] has described an access control system based on RFID in conjunction with face recognition based on neural network. The system recognizes the face of person holding RFID card and denies the access if person is found to be unauthorized. Radial basis function neural network (RBFNN) has been used for learning the face of authorized persons. Principal component analysis (PCA) has been used for extracting the features from the image and linear discriminant analysis (LDA) for refining these features. The network is trained with localized generalization error model (L-GEM) for enhancing its generalization capabilities. Experimental results have shown that proposed system can improve the security of RFID access control. Automatic identification and access control system has become necessary to overcome the security threats faced by many organizations in Pakistan these days. By installing the system at the entrance will only allow the authorized persons to enter the organization. The system can also be installed at various points inside the organization to track the person's movement and to restrict their access to sensitive areas in the organization. In such a way, suspicious persons can be caught which will surely improve the security level in the organization. Radio frequency identification (RFID) is a wireless technology that can be used to develop the access control system. The literature has revealed the use of this technology to automate various processes ranging from industrial sector to home control [1]. Bo Yan [2] has reported the use of RFID technology to automate sight spot ticket management system. The system hardware consists of RFID electronic tickets, RFID readers, computer terminals, optical networks, computer servers and site controllers. Electronic ticket contains the S-DES encrypted form of data including scenic region number, scenic spot number, ticket type, ticket date, site number, serial number and check bit. The RFID reader at the site reads the data inside the e-ticket and transmits it to the computer terminal and servers through the network. The data is decrypted at the terminal and its authenticity is verified. The site controller then allows the right tourist to enter the spot. This system identification and authentication process is carried out at three sub-levels namely the sale sub-system, the decision sub-system and the management sub-system.

All these processes communicate with each other through database information. G. Ostojic [3] has developed an automatic vehicle parking control system based on RFID technology in the city of Novi Sad, Republic of Serbia. The hardware of the system consists of RFID tag and reader operating at a frequency of 13.56MHz for authentication, inductive loop for metal detection, a capacity sensor for counting vehicles, Siemens MC 39i GPRS modem for communication between entrance and exit gates and FEC FC440 programmable logic controller (PLC) which is the heart of the system.

When the car stops on the inductive loop at the entrance, RFID tag is read by the reader. The data on the tag includes the unique identification number (UID), validity period and check bit for checking the parking status. This data is manipulated by PLC and access is granted for parking the vehicle if tagged information contains correct UID, validity period and parking status. After the vehicle has entered the parking lot, its parking status will be changed by the RFID reader/writer to prevent the entry of another vehicle on the same card. The same procedure is repeated when the vehicle is leaving the parking lot. Nova Ahmed [4] has described RFID based indoor guidance and monitoring system known as Guardian Angel in pervasive environment. The beauty of the system is that it can generate dynamic queries in real time through user interface. The environment in the system is equipped with RFID tags and is divided into various zones. The middleware of the system is divided into two layers namely guidance layer and monitoring layer. The guidance layer is provided with handheld RFID reader to provide locality information to the monitoring layer periodically. Thus monitoring layer has the information of the entire environment. Experimental results have shown that system is nearly 100% accurate in providing the zonal information thereby allowing the construction of very robust guidance and monitoring applications. Kuo-shien Huang [5] has described a business model based approach for utilizing RFID technology in automating the process according to enterprise strategic vision and goals. The author has built a business model for bike renting system and used RFID technology to implement the system. The conventional way of getting the bike on rent which includes the recording of customer data by pen and then inputting the data to the computer is replaced by providing a RFID card to the customer and fixing an RFID tag on the bike. The bike is tagged to keep track of its location from the renting store to the return store. The information is shared amongst the stores through web interface. In this way, successful RFID strategy is built and deployed.

#### IV. METHODOLOGY OF THE PROJECT

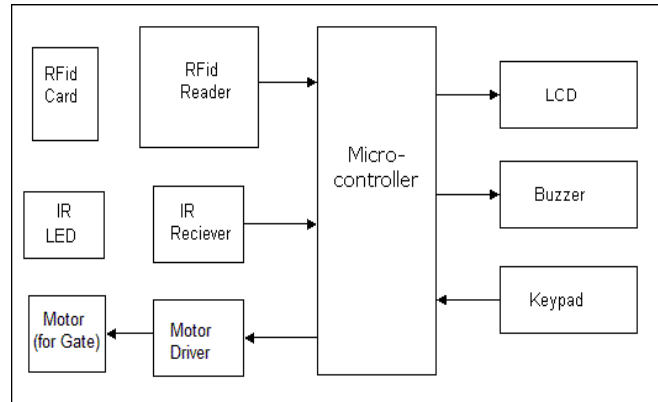

Fig No 01. Shows the generalized block diagram of our project i.e. RFID based highway toll tax collection system.

#### V. DESCRIPTION IN DETAIL:

Description in detail: It mainly consist of following blocks

- ❖ 1. Receiver: We are going to use a Infrared receiver. It is used to detect that vehicle has passed away from the electronic toll collection plaza.
- ❖ 2. Transmitter: Infra-Red transmitters used are IR LEDs. IR rays from transmitters are reflected from the vehicle and are received by the receiver.
- ❖ 3. Microcontroller: This is the CPU (central processing unit) of our project. We are going to use a microcontroller of 8051 family. The various functions of microcontroller are like I. Reading the RFID card number from the RFID reader. II. Sending this data to LCD so that the person operating this project should read various informative messages. III. Sensing the command given using keypad and receiving signal from the IR receiver. IV. Sending the data to the motor or buzzer depending upon the RFID card number and balance inside the card.
- ❖ 4. LCD: We are going to use 16x2 alphanumeric Liquid Crystal Display (LCD) which means it can display alphabets along with numbers on 2 lines each containing 16 characters.
- ❖ 5. DC motor and Motor Driver: We are going to use a DC motor to open the gate. A motor driver IC is required to drive the motor.
- ❖ 6. RFID card reader: This is one of the most important part of the project. It reads the unique



number from the RFID cards and sends it to the microcontroller.

## VI. PROPOSED SYSTEM MECHANISM

Proposed Intelligent Gate system consists of RFID based cards and long range RFID readers with a read range of at least 5 to 7 meters. RFID cards will be fixed on the vehicle windshield which will be encoded with the vehicle identity. This will work as a wireless name plate and will transfer the vehicle identity to the long range reader installed at the gate. Reader will transfer the identity to the application software and instructs the barrier/gate to open or close accordingly. In case the vehicle is unauthorized, a light or audible alarm can be generated.

In this paper our focus on automatic toll deduction system with more features for consumer/driver convenience and time saving. The vehicle will be equipped with Radio Frequency (RF) tag, which will be detected by [12] RF Reader, located on toll plaza. The amount will be automatically deducted from the bank account. A camera will be installed on the toll plaza, camera will take picture of number plate of vehicle which is used for catch the theft vehicle. Speed of vehicle [5] can be controlled using RFID we control the speed of vehicle up to 5 km/h from the time of passing from the toll plaza.

### 1 Design

RFID tag can be installed with number plate; Mount your exterior license plate tag at the top of your front license plate with has faced upward readable position. Figure 3 gives a phenomenal design approach for the research purpose and concept. The Reader (Antenna) or interrogator receives [11] data from the tag which placed on vehicle, reader can have an integrated antenna or the antenna can be separate. Reader is placed on the middle of toll deduction gate and it is connected to Central Server(backend database).Middleware software: Middleware [5 6] software connects reader and the Central server and the data coming from the tags stored in backend database. Middleware sits in the middle of the data flow of information between the reader and backend database of Central server. It is connected to reader which placed outside on the gate of toll plaza. Central servers also connected to LAN (local area network). All computer system of LAN is connected to a central database via a WAN (wide area network). The whole record of toll deduction will be stored at the Central server and monthly transaction will be sent to the consumer from the Central server.

### 2 Account Information

For purchase tags any individual can give application and vehicle of his/her is registered in database and account will be open in bank. All information of bank account and regard to vehicle is stored in tag. Every time vehicle passed from the toll plaza reader fetch information from the tag and toll tax is deducted from bank account. Toll tax is deducted as the type of vehicle is passed means different rates of toll tax for different type of vehicles like cars, vans, trucks, motorcycles etc. To access or update account information the website, automated phone system or through customer service representative, you are required to provide your account number and [5] PIN number. Your account number is included on your statement. Consumer will receive a statement of accounts on the monthly basis. Account statement contain record of total balance, date of open of account, every transaction, date, time location and payment details and also remaining credit of your account. If consumer doesn't deposit credit to his/her account to long time and short credit is remain then he will receive a message of short credit by email or phone alert.

### 3. Working

In RFID based toll deduction system a vehicle arrive in toll plaza range antenna send signals to tag and activate the tag, tag send back information to antenna. As data receive to antenna [9] it sends to central server database. Server checks information of account consumer/driver, if account has credit more than required tax then tax is subtract from account and driver will pass the toll plaza. A transaction message also sends to consumer/driver that how much tax is paid and remaining balance of account. Passing of vehicle and transaction of tax is completed within short time. The central server stores all information of transaction, which contain location of toll plaza, date, time and total amount payment of tax. If the credit of account is low then system generates indication for low balance. The speed limit for passing from toll plaza is not constant on every toll plaza because some companies are set speed limit 86kilometers per hour (5 mph) and some company's set speed limit to 48 kilometers per hour or low 8kilometers per hour. Video cameras are installed on the toll plaza for the observation that any consumer cannot pass without having tag in vehicle. Any consumer/driver pass from toll plaza then camera capture picture of number plate and send abuse notice to the owner of vehicle through the email. Highlights the above discussed procedures with specific tag, camera and gate positions.

### 4. Vehicle Speed Control through RFID

RFID can also be implemented in vehicles to control the speed of the car. Such system can be named as automatic vehicle speed control system. The vehicle will be equipped with a radio frequency (RF) reader which will detect RF transmitters located on the speed limit signs posted on the side of road. The vehicle will then automatically adjust is

speed so as to obey the speed limit for that particular stretch of road. This project can be considered scalable to implement in motor vehicles used today, an overview of system.

## VII. RFID WORKING

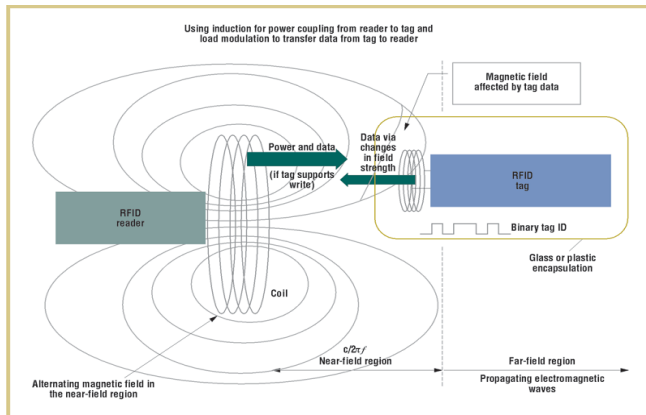

Fig No 02. Shows the generalized block diagram of our project i.e. RFID based highway toll tax collection system

### 5. Reducing Car Theft

RFID can provide an effective deterrent against car [5] theft. A solution for this type I characterized by the following: Attaching a tag to vehicle to be monitored for theft. Reading the tag ID at the vulnerable points (for Example, at exit points, during starting of the ignition of an automobile, and so on). An application for this is automotive anti-theft immobilization. In this commercially deployed solution, an embedded reader located inside the car (for example, in the steering wheel) becomes activated when a driver turns the ignition key. This reader then attempts to read the valid unique code from a tag in its vicinity.

### 6. Comparison with Previous Mechanisms

So many new projects are done through us in RFID and so many manual systems are now automated by using the technology of RFID. In previous work of RFID is that make manual system to automate for time saving and keep record up to date. For example Student attendance system, students attend the class then their attendance is counted in database and their timing of arrival and leaving. In previous toll deduction system only simple way tax is deducted from the account. But further implementation or scaling of project of toll deduction system is stop the anti-theft of vehicle and control the speed of vehicle by using RFID technology. Also keep stop violation of rules if any vehicle did not have tag then camera takes snapshot of vehicle and send alert to next station of toll plaza to catch the vehicle.

## VIII. APPLICATIONS

1. This project can be used in Toll collection plaza on Highway.
2. Can be used in octrai collection booths for faster access.
3. Makes travelling more convenient, reduces travel times especially during festive seasons when traffic tends to be heavier than normal.
4. Increase highway capacity. Processes 250 – 300% more vehicles per lane, reducing delays and traffic congestion.

## IX. FUTURE SCOPE

1. We can send this data to a remote location using mobile or internet
2. Voice alarm system can be added to indicate that room is full & persons can't enter inside.

## X. CONCLUSION

The improvement of RFID based toll finding framework is demonstrated that RFID innovation have great results in actualizing in various applications however the standard organization have add to the system of uses. In this toll derivation framework RFID is utilized allowed recurrence groups by utilizing high power levels, then framework will be fruitful. The organizations which have authorizations from the powers since tag is utilize the financial balance and enlistment quantities of vehicles. For this application a loof tag are superior to dynamic label in view of minimal effort furthermore radio signs ecological elements. For the future work RFID speed controlled framework vehicle can be spare from the mischance because of fast. A few works will be done auto directing arrangement of vehicle which can be controlled by utilizing RFID innovation introduced on the complete track. This will be useful if transport driver have significant issue of heart assault or other infection all of a sudden then control exchange to programmed RFID correspondence framework. Some work must be on RFID correspondence range between the Reader/reception apparatus and tag is constrained into few meters it will be reach out to long range.

## REFERERNCES

- [1] <http://www.psfk.com/2010/05/using-rfids-to-take-student-attendance.html>
- [2] <http://rfid.thingmagic.com/rfidblog/?Tag=Railway+Management>
- [3] [http://www.upmraflatac.com/northamerica/eng/news/presenter/2009/43\\_72708.asp](http://www.upmraflatac.com/northamerica/eng/news/presenter/2009/43_72708.asp)

- [4] <http://www.b-eye-network.com/view/5672>
- [5] Frank Thornton, Brad Haines & Anand M. Das "RFID Security" Syngress publishing, Canada, April, 2006.
- [6] Himanshu Bhatt, Bill Glover "RFID Essentials" publisher: O'Reilly. January 2006
- [7] Sandip Lahiri, "RFID Sourcebook" Publisher: Prentice Hall PTR. August 31, 2005, ISBN: 0-13-185137-3.
- [8] OTA Training, Eva Zeisel, Robert Sabella. "RFID+Exam Gram" Publisher: Que, May 16, 2006
- [9] Patrick J. Sweeney II "RFID for Dummies" Wiley Publishing, Inc. Indiana ISBN: 0-7645-7910-X, 2005.
- [10] Yan Zhang, Paris Kitsos, "security in RFID and Sensor Network (wireless Networks and Mobile Communication)" Auerbach Publications, 2009. ISBN: 1420068393.
- [11] S Jaya Krishna, "RFID: applications and cases" Publisher: Icfai University press Hyderabad, India. 2010.

