

A Smart Prepaid Anti-theft Energy meter

^[1]Ann Mary Michael, ^[1]Mathews Mathew, ^[1]Raghav Nath, ^[1]Reeja Mathew, ^[1]Rohit Koshy Roy
Department of Electrical and Electronic Engineering Amal Jyothi College of Engineering Kanjirapally,
Kottayam, Kerala

Abstract: Power utilities in different countries are incurring huge losses due to electricity theft. This paper proposes the control of electricity theft by using a prepaid energy metering system. In this system a smart energy meter is installed in every consumer unit and at the service provider side a server is maintained. The meter and the server are equipped with GSM module which facilitates bidirectional communication. By sending a PIN number hidden in a scratch card to the server using SMS consumers can easily recharge their energy meter. The bidirectional GSM communication using SMS ensures the effectiveness of these measures. Pilferage of electricity can be substantially reduced by incorporating the proposed measures along with the prepaid metering scheme. Legal actions against dishonest consumers are also taken in this system.

Keywords: electricity theft; prepaid meter; GSM networks; SMS; smart energy meter; recharge card

I. INTRODUCTION

As we all know that in INDIA we are getting shortage of electricity. In that case also some of our consumers are trying to have theft by short circuiting the energy meter. In our country majority of our people are middle class range. So that people will try to maintain the cost to limited range by using these kind of methods. In other countries this kinds of methods or the advance technology has being installed so it is easy to catch these kind of consumers.

Different types of technical and nontechnical procedures were proposed to control energy theft. But due to limited time and lengthy procedures, such processes or methods have been proven futile. Electricity theft usually takes place in the form of tampering, in this method the user tries to open the main box within which connection are made.

Second method is to bypass the whole meter or by shorting the phase or by disconnecting the neutral. This prevents the energy meter from reading the load consumption.

Third trend we see now a days is of non-payment of bills. Consumers sometimes do not pay bills regularly. This results in loss of revenue and will prove to be a burden for service provider.

II. PROPOSED ENERGY METER

The energy meter consist of PIC16F877a microcontroller to control processes involved in energy meter operation. It also consist of ADE7751 energy chip which converts corresponding units to pulses. A GSM module for bidirectional communication

from the service provider to the consumer and vice versa so that it is easy to obtain the readings as well as the information that both the sides to know. We got components like LCD display, mobile, GSM-module, etc. The programs that are done using the embedded C programming.

Here we are trying to make two things together they are:

1. To control the theft that is going around us so that we are able to understand a better way to tackle it.
2. That we could have a pre-paid meter which has the ability to communicate with provider and the consumer as well as the consumer is able to obtain the readings, the consumed energy in kWh, the warning message to recharge the energy meter such that he will be able to continue using his usage without break in the supply that comes to his or her household.

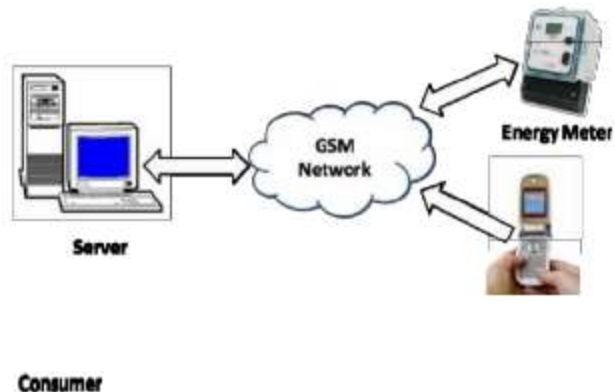

Fig1. Basic Principle

The above shows the basic diagram between the consumer,

energy meter and the provider as we see here all the three is mainly connected to a GSM network which will be acting as the centre. GSM will communicate between all the three sending of the message will be taken place over here.

In case of the recharging the energy meter it will be almost same like what we are doing in our mobile phone recharge for example if we recharge our energy meter with a 100 units. Then as we start using the energy meter it will reduce the corresponding units from 100, as we reach around 10 units the consumer will receive a message that user should recharge their energy meter to continue using of the supply.

If he does that then the service provider as well as the consumer will know that he has recharged the energy meter with another 100 units. If he or she doesn't do that then the connection could be cut off by using a relay which will be kept at the consumer's end which will be able to control by the service provider but not by the consumer.

The above shows the basic block diagram of the energy meter in our houses.

The theft that could be done by different methods such as

1. Phase bypassing.
2. Tampering the meter.
3. Bypassing the whole meter

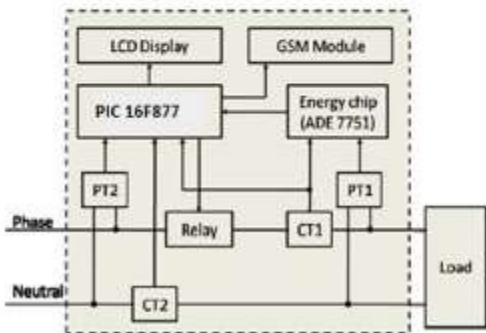

Fig 2 Block diagram of proposed energy meter

PHASE BYPASSING

The energy meter can be prevented from taking reading by shorting the phase. To take care of it we have used a CT and a PT at the supply end and at load end. When shorted the ADE will not get any reading. This will enable an interrupt in microcontroller which will send a message to utility about the tampering of the system. Here we taking into considerations of

two CT which are kept at the points where the measurement are taken before and after the meter such that we are given the output of both the CTs to the microcontroller such that we are able to find the difference.

If the difference is observed then we could understand that the meter has been short circuited such that we are able to cut the relay from the service provider. Here we are also able to cut the neutral wire that will be passing outside the energy meter such that there won't be any reading for the energy meter and this will be able to make a good theft. This theft is difficult to find out using the old energy meter that we are using in our households.

The two current transformer that we have connected will be looking after this thing has we see here the CT1 will be reading the phase current but the CT2 will not be reading this. Thus it will be easy to note the difference between two current transformers and we are able to disconnect the meter from the supply. Which will make the consumer not to get supply for the loads.

The supply will be disconnected by using the microcontroller by using the interrupt pin. The controller will be programmed in this way to find out these kind of activities that will be done by the consumers.

TAMPERING THE METER

To show low or no energy consumptions consumers or professional ones may try to open the energy meter and tamper it. To get rid of this problem, two lever switches are used at two sides of the proposed energy meter. One terminal of each lever switch is connected to 5V dc supply and the other one is connected to the microcontrollers interrupt pin.

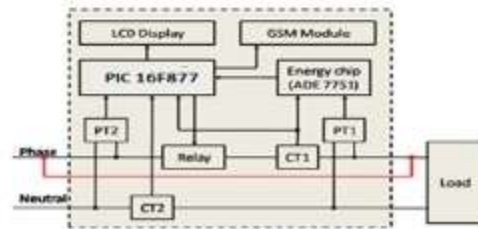

Fig 3.Phase bypassing energy meter

In normal conditions, the two lever switches will be closed and the microcontroller will detect 5V at its two input pins. If consumer tries to open the energy meter the lever switches are disconnected and the microcontroller will detect 0V at its input pins. If this occurs, the microcontroller immediately notifies the server and disconnects the load from the supply.

BYPASSING THE WHOLEMETER

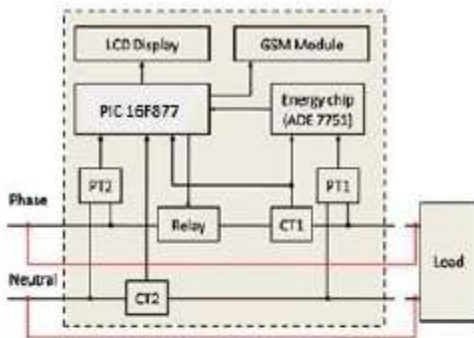

Fig 4. Whole meter Bypassing

In this case the bypassing the whole meter there won't be any reading of the meter is available thus the bypassing these kind of things is difficult to do using the energy meter. This is beyond the control. To prevent this kind of theft, our proposed energy meter takes several steps. The output of PT2 is converted to 5V dc and is given to the interrupt pin of the microcontroller. When the whole meter is bypassed PT2 detects no voltage and an interrupt is sent to the microcontroller. The energy meter then requests the power status of the area, where the meter is located, to the server. If the server confirms that the power supply is available in that area, then the meter immediately disconnects the load and informs the server of the electricity theft. During the whole operation backup from a rechargeable battery is available

CONCLUSION

In this paper, we have proposed a prepaid energy meter Which takes advantage of the GSM network that has virtually Access to every household and area across different countries. The GSM communication not only implements the idea of meter is thus highly useful for power utilities for reducing Electricity pilfering and ensuring revenue al. Utilities to control energy theft using our smart energy meter. In this system, the information of electricity theft is directly prepaid Consumption of electricity but also facilitates the reported to the central authority.

ACKNOWLEDGMENT

The authors would like to thank the Department of Electrical And Electronic Engineering, Amal Jyothi College of Engineering, for providing laboratory facilities and opportunity for experimental setup.

REFERENCES

- [1] T. B. Smith, "Electricity theft: a comparative analysis," Elsevier Journal Energy Policy, vol. 32, no. 18, pp. 2067-2076, Dec. 2004.
- [2] A. J. Dick, "Theft of electricity-how UK electricity companies detect and deter," in proceedings of European Convention on Security and Detection, pp. 90-95, May 1995.
- [3] C.J. Bandim, J.E.R. Alves Jr., A.V. Pinto Jr., F.C. Souza, M.R.B. Loureiro, C.A. Magalhaes, and F. Galvez-Durand, "Identification of energy theft and tampered meters using a central observer meter: a mathematical approach," in proceedings of IEEE PES Transmission and Distribution Conference and Exposition, vol. 1, pp. 163-168, Sept.2003.
- [4] S.S.S.R. Depuru, L. Wang, and V. Devabhaktuni, "A conceptual design using harmonics to reduce pilfering of electricity," in proceedings of IEEE Power and Energy Society General Meeting, pp. 1-7, Jul. 2010.
- [5] J. Nagi, K.S. Yap, S.K. Tiong, S.K. Ahmed, and A.M. Mohammad, "Detection of abnormalities and electricity theft using genetic Support Vector Machines," in proceedings of IEEE Region 10 Conference, pp. 1- 6, Nov. 2008.
- [6] A.H. Nizar and Z.Y. Dong, "Identification and detection of electricity customer behaviour irregularities," in proceedings of IEEE Power Systems Conference and Exposition, pp. 1-10, Mar. 2009.
- [7] A.Pasdar and S.Mirzakuchaki, "A solution to remote detecting of illegal electricity usage based on smart metering," proceedings of 2nd International Workshop on Soft Computing Applications, pp. 163-167, Aug. 2007.
- [8] A. Barua, N. Mohammad, A. I. Abbas, and M. A. Arafat, "Single phase SMS prepaid digital energy meter," unpublished
- [9] A. Barua, N. Mohammad, M. A. Arafat, K. Khan, A. I. Abbas, and R. Chaudhary "Threephase SMS prepaid digital energy meter," International Conference on Electrical and Computer Engineering, Dec. 2012, in press.
- [10] S.S.S.R. Depuru, L. Wang, V. Devabhaktuni, and N. Gudi, "Measures and setbacks for controlling electricity theft," in proceedings of North American Power Symposium, pp. 1-8, Sept. 2010.