

# Photovoltaic Power Control Using MPPT Technology

<sup>[1]</sup>Teena Varghese <sup>[2]</sup>Nithu Thankam Johnson <sup>[3]</sup>Anju Susan Moses <sup>[4]</sup>Lintu Merin Philip

<sup>[1][2][3][4]</sup>Department of Electrical and Electronics Engineering

Amal Jyothi College Of Engineering, Kanjirappally

<sup>[1]</sup>teenavchry@gmail.com <sup>[2]</sup>johnsonnithu12@gmail.com <sup>[3]</sup>anjususanmoses24@gmail.com <sup>[3]</sup>lintu415@gmail.com

**Abstract:** Use of electricity is increasing day by day. Converting solar energy into electrical energy is one of the best ways to reduce fossil fuel consumption. The solar irradiance and temperature are dynamic. Several studies suppose that more than 45% of the energy in the world will be generated by photovoltaic array. The electricity finds its application in all the domains. The main advantages of photovoltaic (PV) systems employed for harnessing solar energy are lack of greenhouse gas emission, low maintenance costs, fewer limitations with regard to site of installation and absence of mechanical noise arising from moving parts. PV systems suffer from relatively low conversion efficiency. Therefore, maximum power point tracking (MPPT) for the solar array is essential in a PV system. The nonlinear behavior of PV systems as well as variations of the maximum power point with solar irradiance level and temperature complicates the tracking of the maximum power point. A variety of MPPT methods have been proposed and implemented. Therefore a Maximum Power Point Tracking (MPPT) technique is needed to maximize the produced energy. A P&O method is the most simple, which moves the operating point toward the maximum power point periodically increasing or decreasing the PV array voltage. A Mat lab-Simulink based simulation study of PV cell/PV module/PV array is carried out and presented.

**Keywords:** Heat radiation, Seebeck Effect, Temperature gradient, Thermoelectric generator (TEG), Power generation

## I. INTRODUCTION

Solar energy is one of the most important renewable energy sources. Solar energy is clean, inexhaustible and free. The photovoltaic (PV) domain provide one of the most efficient ways of producing energy, with real perspectives in the future, considering the actual situation of the classical power resources around the world. Usually, when a PV module is directly connected to a load, the operating point is rarely at the maximum power point or MPP. The PV array is an unregulated dc power source, which has to be properly conditioned in order to interface it to the grid. The dc/dc converter is present at the PV array output for MPPT purposes, i.e. for extracting the maximum available power for a given in solutions level. A photovoltaic system converts sunlight into electricity. The basic device of a photovoltaic system is the photovoltaic cell. Cells may be grouped to form panels or modules. The continuous increase in the level of greenhouse gas emissions and the climb in fuel prices are the main driving forces behind efforts to utilize various sources of renewable energy. The main applications of photovoltaic (PV) systems are in either stand-alone (water pumping, domestic and street lighting, electric vehicles, military and space applications) or grid-connected configurations (hybrid systems, power plants). Utilizing PV systems as an alternative source of energy requires a substantial amount of investment. In order to reduce the overall cost of PV systems, therefore, extraction of the maximum power from a solar cell turns out to be a vital consideration for optimal system design. The

maximum output power depends on the radiation intensity, ambient temperature and load impedance. There is a single operating point enabling attainment of maximum power, tracking of which through variations in radiation intensity and temperature is essential in order to ensure the efficient operation of the solar cell array. The fundamental problem addressed by MPPT is to automatically determine the PV output voltage or output current for which the PV array produces maximum output power under a given temperature and irradiance. Attainment of maximum power involves load-line adjustment under variations in irradiation level and temperature. Maximum Power Point Tracking, frequently referred to as MPPT, is an electronic system that operates the Photovoltaic (PV) modules in a manner that allows the modules to produce all the power they are capable of. MPPT is not a mechanical tracking system that "physically moves" the modules to make them point more directly at the sun. MPPT is a fully electronic system that varies the electrical operating point of the modules so that the modules are able to deliver maximum available power. The maximum power point tracking, MPPT not only enables an increase in the power delivered from the PV module to the load, but also enhances the operating life time of the PV system. A variety of MPPT methods have been developed and implemented. These methods can be differentiated based on various features including the types of sensors required, convergence speed, and cost, range of effectiveness, implementation hardware requirements, and popularity. In essence, however, different MPPT methods can be categorized offline methods, which are dependent on solar

cells models, online methods which do not specifically rely on modeling of the solar cell behavior, and hybrid methods which are a combination of the aforementioned methods. The offline and on line methods can also be referred to as the model based and model free methods, respectively. Perturbation and Observation (P&O) can track the Maximum Power Point (MPP) all the time, irrespective of the atmospheric conditions, type of PV panel, and even aging, by processing actual values of PV voltage and current. Since the cost of the required circuitry for implementing on-line MPPTs is higher, they are usually employed for larger PV arrays. P&O method is widely used in PV systems because of its simplicity and easy of implementation. However, it presents drawbacks such as slow response speed, oscillation around the MPP in steady state, and even tracking in wrong way under rapidly changing atmospheric conditions.

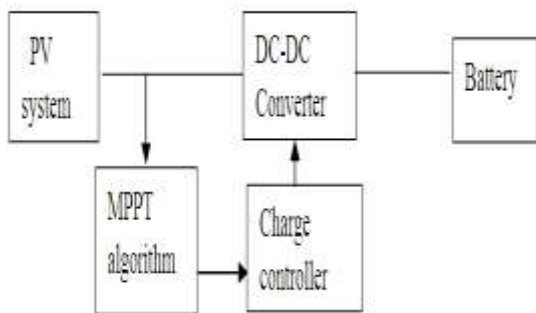

## II. PHOTOVOLTAIC MODEL

The equivalent circuit of the general model which consists of a photo current, a diode, a parallel resistor expressing leakage current, and a series resistor describing an internal resistance to the current flow in the circuit. A solar cell, which is basically a p-n semiconductor junction directly, converts light energy into electricity. PV cells are grouped in larger units called PV modules, which are further interconnected in a parallel-series configuration to form PV arrays or generators.

The current- voltage characteristic equation of a solar cell is given as

$$I = I_{ph} - I_{se} \exp \left[ q \frac{(V + I R_s)}{k T C} \right] - \frac{(V + I R_s)}{R_{sh}} \dots (i)$$

Where,

$I_{ph}$  = Light-generated current or photocurrent,

$I_{se}$  = Cell saturation of dark current,

$q = 1.6 \times 10^{-19} C$ ,

$k$  = Boltzmann's constant  $1.38 \times 10^{-23} J/K$ ,

$TC$  = Cell's working temperature,

$A$  = Ideal factor,

$R_{sh}$  = Shunt resistance

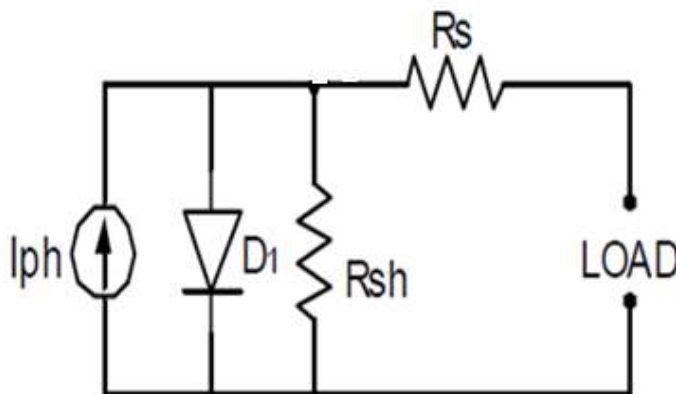
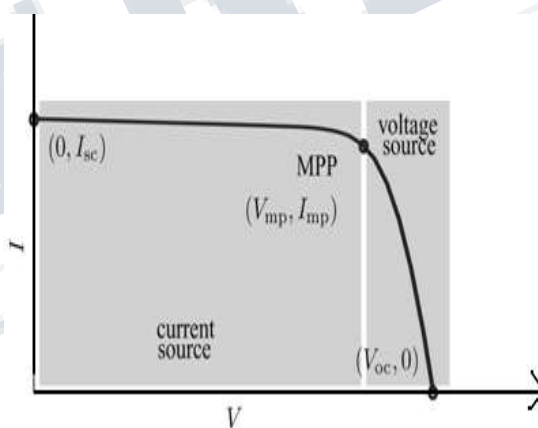

Fig:PV Cell Circuit Model

The complete behavior of PV cells are described by five model parameters which is representative of the physical behavior of PV cell/module.

I-V characteristics



## III. DESIGN OF BOOST CONVERTER

Boost converter is also called as the step up converter as output of Boost converter is always greater than that of the input. Boost converter consists of input voltage source, switch, inductor, diode, capacitor and resistor which acts as a load. The switch can be closed or open depends on the output requirement. The output voltage across the load or resistor is always greater than that of input voltage. A boost regulator can step up the voltage without a transformer. Due to a single switch, it has a high efficiency. The input current is continuous. The output voltage is very sensitive to changes in duty cycle  $D$  in equation. The average output current is less than the average inductor current by a factor of  $(1-D)$ , and a much higher rms current would flow through the filter capacitor

#### IV. MPPT TECHNIQUES

MPPT techniques are needed to maintain the PV array's operating at its MPPT. Many MPPT algorithm are there to obtain the maximum power point of PV cell as listed below.

##### 1. Offline methods

In offline methods, also known as model-based methods, usually the physical values of the PV panel are used to generate the control signals. These methods that only are used for PV systems are open circuit voltage method (OCV), short circuit current method (SCC) as well as the MPPT method based on artificial intelligence (AI).

##### 2. Hybrid Methods

The hybrid methods are expected to track MPP more efficiently. In these methods, the control signal associated with the algorithm consists of two parts. Each part is generated based on a separate algorithmic loop. The first part is determined according to one of the simplified offline methods as a constant value, which depends on the given atmospheric conditions of the PV panel and represents the fixed steady state value. This part of the control signal is intended to follow the MPP approximately and is only required to present a fast response to the environmental variations. This part can be generated using one of the previous offline methods or simplifications thereof based on the relationship between output power characteristics and ambient. The second part of the control signal, which could be obtained based on one of the online methods involving steady state searches, represents attempts to track MPP exactly.

##### 3. Online methods

In on line methods, also known as model free methods, usually the instantaneous values of the PV output voltage or current are used to generate the control signals. The online methods Perturbation and observation method (P&O), extreme seeking control method (ESC) and as well as the incremental conductance method (IncCond) will be reviewed in this work.

##### 3.1 Perturbation and Observation:

Perturb and Observe (P&O) is one of the most diffused MPPT algorithms, whose tracking response is independent on the environmental conditions, however, its implementation requires a voltage and a current sensor, increasing the cost and complexity. P&O algorithms are widely used in MPPT because of their simple structure and the few measured parameters which are required. They

operate by periodically perturbing (i.e. incrementing or decrementing) the array termed voltage and comparing the PV output power with that of the previous perturbation cycle. If the power is increasing, the perturbation will continue in the same direction in the next cycle, otherwise the perturbation direction will be reversed. MPPT cycle, therefore when the P&O is reached, the P&O algorithm will oscillate around it resulting in a loss of PV power, especially in cases of constant or slowly varying atmospheric conditions. This problem can be solved by improving the logic of the P&O algorithm to compare the parameters of two preceding cycles in order to check when the P&O is reached, and bypass the perturbation stage. Another way to reduce the power loss around the P&O is to decrease the perturbation step, however, the algorithm will be slow in following the P&O when the atmospheric conditions start to vary and more power will be lost.

#### V. PERTURB AND OBSERVATION ALGORITHM

The perturb and observe (P&O), as the name itself states that the algorithm is based on the observation of the array output power and on the perturbation (increment or decrement) of the power based on increments of the array voltage or current. In this method a slight perturbation is introduced to the system. This perturbation causes the power of the solar module to change. If the power increases due to the perturbation then the perturbation is continued in that direction. After the peak power is reached the power at the next instant decreases and hence after that the perturbation reverses. When the steady state is reached the method oscillates around the peak point. In order to keep the power variation small the perturbation size is kept very small.

#### VI. SIMULATION OF MODEL IN SIMULINK

Simulation is a process in which the circuit works and verifies the output values. Modelling of solar cell or PV cell divided into two parts Behavioral PV modeling and Power limited electrical driver. The behavioral model of proposed PV model is based on this equivalent electrical circuit model. Current source,  $I_{ph}$ , which is a current produced by the photons, is constant at a fixed value of radiation and temperature. Perturb and observation maximum power point tracking algorithm is developed using SIMULINK software. It consists of Solar panel, MPPT block and at the end Boost converter. MPPT block is heart of this work which helps in determining the maximum operating point and also gives the gate signal to the Boost converter. Boost converter helps to maintain the operating voltage at the maximum power point.

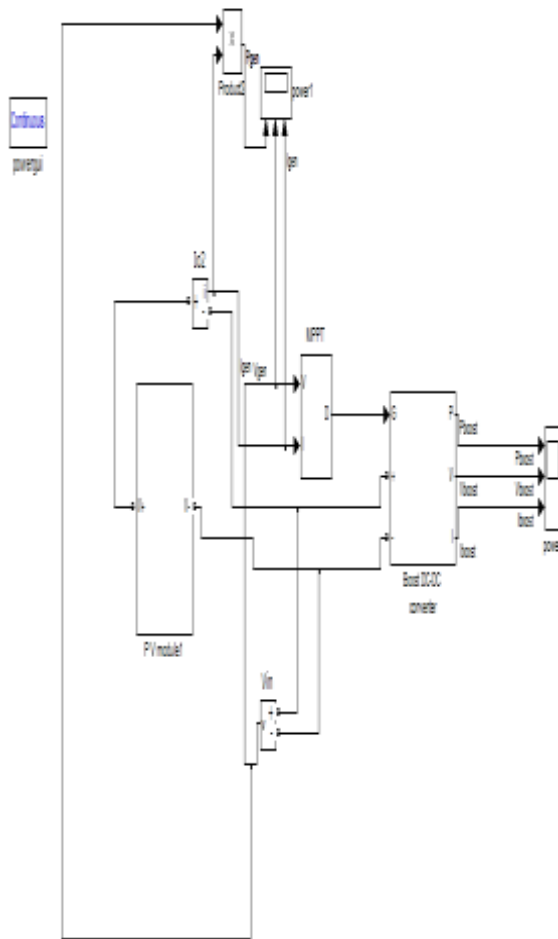
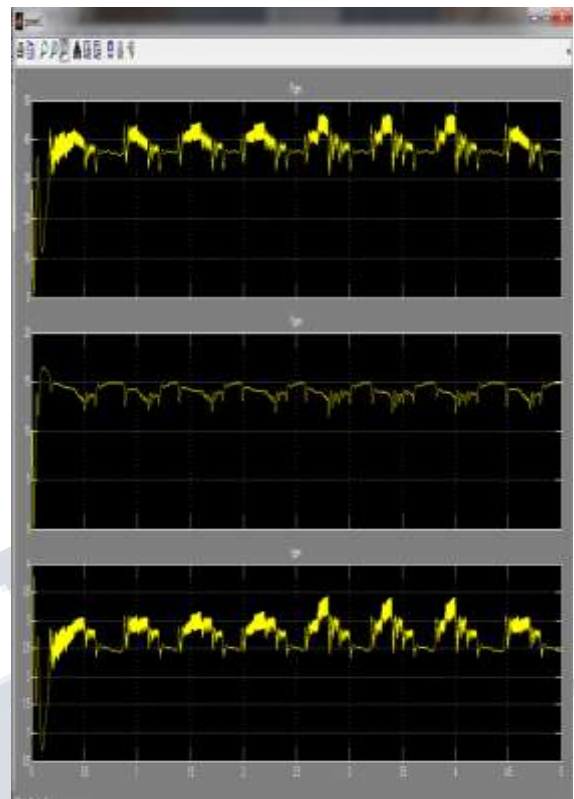

Fig: SIMULINK model of perturb and observation MPPT algorithm

**VII. SIMULATION RESULTS**

The simulation output waveform form without and with MPPT block is as shown in figure 10 and 11 respectively. It is clear from waveform that at normal operating condition of PV panel output power changes as the solar irradiance varies. This is the condition when the MPPT block and Boost converter is not present. With MPPT block and Boost converter output power remains at maximum power point even though solar irradiance varies.



(a) Without MPPT

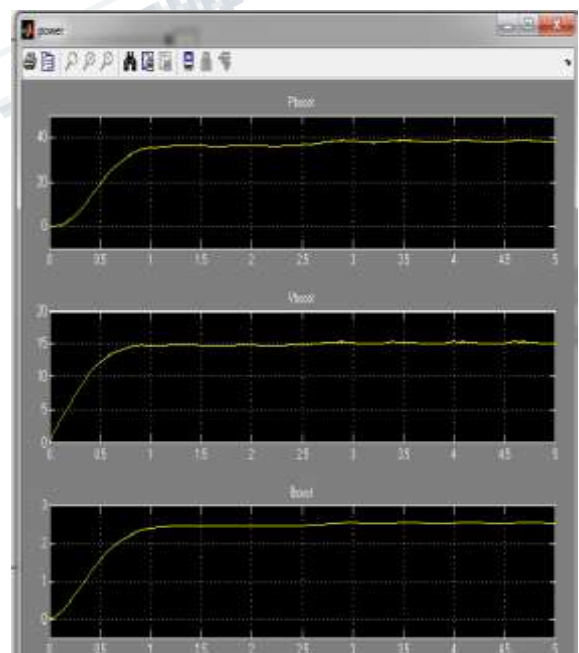

(b) with MPPT

**VIII. CONCLUSION**

The proposed model is established in SIMULINK software, and output characteristics of photovoltaic array is studied and analyzed. Mainly perturb and observation MPPT algorithm is used to obtain the maximum power point of solar array. Boost converter is used to obtain this maximum power point which helps in step down the array voltage to the maximum operating point voltage. So by using MPPT algorithm and boost converter solar array is operated at maximum power point irrespective of solar irradiance. Further we can also design the inverter circuit which converts the DC power into AC power. And this can be connected to grid with the help of inverter. The PV system in solar cell does not produce pollution, have no moving parts, and consume no fossil fuel during power generation. The present research paper describes the programming of the PV system and Matlab/Simulation of the Perturb and Observe technique of MPPT and DC-DC buck converter for charging the battery. This charged battery can be used at night, during rainy days and in winters. Therefore, it is our wish to make the PV system more efficient so that it can help for betterment of life.

