

Augmentative and Alternative Communication (AAC) Device for People with Communication Disorder

^[1]Deepika T V, ^[2]Sowjanya M N, ^[3]Amrutha R

^{[1][2]} Assistant Professor

^{[1][2][3]} Dept. of E&IE, GSSS Institute of Engineering & Technology for Women,

Abstract:-- Communication involves sharing of one's desires, thoughts and humors. People suffering from autism, cerebral palsy or with speech disorders, have inability to communicate and this impacts on their quality of life, education and social relationships. The frustration caused by these would lead to behavioral changes. To favor such people, augmentative and alternative communication (AAC) device is designed which can provide such people an opportunity to express themselves and have effective communication. For people who have disabilities of speaking, augmentative and alternative communication device provides a means of communication. A person who is dependent on augmentative and alternative device can communicate easily about their desires at any time.

Index term:—Autism, Cerebral palsy, augmentative and alternative communication.

I. INTRODUCTION

The term used to describe the communication methods which support or replace speech is augmentative and alternative communication. To understand the world around the people who have speech disorders, to express their views to communicate in their workplace augmentative and alternative device helps them. For people with communication disability, intellectual or physical disability, brain injury or neurological disability, augmentative and alternative communication device can be suggested.

Augmentative and alternative communication device can be broadly classified into unaided AAC, non-electronic AAC and electronic AAC. Unaided AAC: These types of augmentative and alternative communication device do not require any assistive devices. This can be classified into: Keyword signing: these are used to communicate with people who can hear but cannot speak, who have difficulties in understanding and who are difficult to understand. Here hand signs and gestures are used. Body sign: For people having both sight and hearing impaired, individualized signs are performed onto hands or other part of persons body. Touch clues: To help people to understand the activities, contacts on their body are made.

Non electronic AAC: The use of pictures, symbols, spellings and phrases to communicate is non electronic AAC. This include,

- ❖ Visual strategies used to request things, actions and make choices.
- ❖ Communication boards, which have one page boards which help in making longer sentences.
- ❖ Communication books feature lists of words organized into a book.
- ❖ Communication access cards that are as business cards which are used to describe a person's disabilities.
- ❖ Electronic AAC: The use of any electronic equipment to communicate is electronic AAC. They include,
- ❖ Microphones and voice amplifiers placed near the person's mouth or voice box for amplification of voice.
- ❖ With the combination of symbols, photos and words speech generating devices are used to create message that has to be spoken. This voice may be either recorded message or synthesised voice that is available.

The purposes of AAC are

- ❖ Augmentation of communication for people with unintelligible speech.
- ❖ Providing alternative mode of communication for people with speech disorder.

Associated conditions with complex communication needs and AAC needs include,

1. Autism
2. Cerebral palsy
3. Intellectual disability and

4. Developmental apraxia.

“30-50% of children with a diagnosis of autism will fail to acquire any appreciable amount of speech and will therefore require AAC” says National Research Council in the year 2001.

Augmentative and alternative communication device may also be required for people with acquired disorders, such as

1. For people with acquired brain injury.
2. Individuals with neurological disorder.
3. People suffering from stroke or spinal cord injury.

Finally, there are numerous temporary conditions that could require the use of augmentative and alternative communication device including surgery and other situations that result in temporary speech loss.

A. Objective:

The objective of the present project is to help the people with communication disorders using the RF module which recognises the input with the help of the transmitter and receives the signal with the help of receiver and outputs it.

B. Scope of the project:

When a person is suffering from cerebral palsy, autism or any other neural disorder, he will not be able to talk. This project helps them to express their needs, hopes and ideas to connect with their families and friends, to communicate in the work place, access education, understand more about the world around them and direct others who care for them.

II. PROPOSED METHODOLOGY

AAC devices are useful for individuals with speech and language disorders to communicate. In this work we are replacing the touch screen AAC boards by a neck loop which consists of several push buttons. The whole system is fabricated on to a leather material which forms a loop around the neck. In this we are interfacing RF module with 8051 microcontroller to get a speech output through a speaker. A push-button is a simple switch used for controlling a process. Push-Buttons are typically made out of hard material, usually plastic or metal.

A 9V power supply is used in this system; this voltage is regulated to 5V using 7805 voltage regulator which is connected to 8051 microcontroller and RF module. In 7805 IC, there are 3 pins, pin 1 takes the input voltage and the output voltage is produced by pin 3. The GND of both pin 1 and pin 3 are given to pin 2.

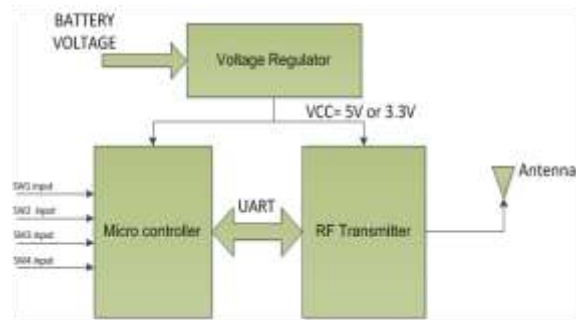

Fig 1: Block diagram of transmission section

Fig 1 shows the block diagram of the transmission section. It consists of 7805 voltage regulator, 8051 microcontroller and RF transmitter. When push button is pressed, the metal strip gets connected and the result will be high, when depressed, there will be no connection inside and result will be false. When result becomes high the signal is given to microcontroller which compares the received data with the predefined data. The compared data is given to the RF transmitter. In this device we use the four ports of the 8051 microcontroller which provides the serial communication between the transmitter and receiver.

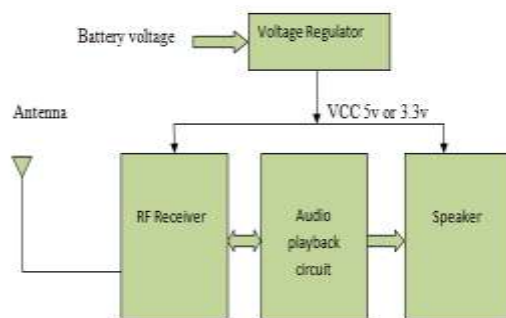

Fig 2: Block diagram of receiver section

Fig 2 shows the block diagram of receiver section. It also consists of 7805 voltage regulator and 8051 microcontroller along with RF receiver and speaker. The RF receiver receives the information from the transmission section and plays it on the speaker. Speakers are the output devices which produces audio output that can be heard by the listeners.

Using this, it improves the self esteem of people suffering from cerebral palsy, autism and speech disorders. They help the users to increase their participation in daily life. It also motivates users to learn how to communicate and help them to interact with others.

III. RESULT

Augmentative and alternative communication device is a unique project with many future work involved in it for convenience for people with communication disorder. Fig 3 shows the snapshot of the project.

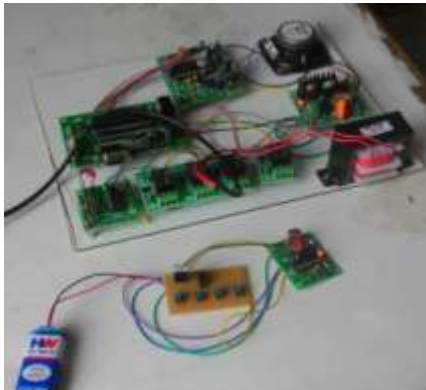

Fig 3 Snapshot of the project

When one of the four push buttons is pressed, then the information gets transferred to the RF transmitter and then gets received by the receiver. The preloaded message in the audio feedback circuit gets played through the speaker.

IV. DISSCUSSION AND CONCLUSION

AAC devices provide an alternative and effective method of communication for people suffering from communication disorders like cerebral palsy, Autism etc. This device helps such people to express their needs, ideas and to communicate with their family, friends and people around them. It also helps them to understand more about their surroundings. This device is cost effective as it uses simple components like push buttons, voltage regulators and RF module. The existing system is bulky and has many options, this disadvantage can be overcome by the proposed work which is light and has basic minimal options.

Acknowledgements

The current work was made possible because of the grant provided by **Vision Group On Science and Technology**, Department of Information Technology, Biotechnology and Science & Technology, Government of Karnataka, Grant No.VGST/CISEE/2012-13/GRD188/282. We acknowledge the VGST for sanctioning a grant amount of **Rs. 30 Lakhs** for the “Establishment of Innovative Robotics Awareness Lab” at **GSSS Institute of Engineering and Technology for Women**, Mysuru, Karnataka, India.

REFERENCES

- [1] Simon Judge and Gillian Townend, Perceptions of the design of voice output communication aids International Journal of Language & Communication Disorders (April 2013)
- [2] D. Beukelman and P. Mirenda, Augmentative and alternative communication Vol. ISBN 1-55766-333-5
- [3] H. S. Venkatagiri, Clinical Implications of an Augmentative and Alternative Communication Taxonomy Augment Altern Commun In Augmentative and Alternative Communication, Vol. 18, No. 1.
- [4] Pat Mirenda, Toward functional augmentative and alternative communication for students with autism: manual signs, graphic symbols, and voice output communication aids Lang Speech Hear ServSch, Vol. 34, No. 3.
- [5] Michael Clarke and Andrea Kirton, Patterns of interaction between children with physical disabilities using augmentative and alternative communication systems Child Language Teaching and Therapy, Vol. 19, No. 2.
- [6] Katya Hill, A case study model for Augmentative and Alternative Communication outcomes Assistive Technology Outcomes and Benefits, Vol. 3, No. 1.
- [7] T. Falk, J. Chan, P. Duez, G. Teachman, T. Chau Augmentative Communication Based on Realtime Vocal Cord Vibration Detection IEEE Transactions on Neural Systems and Rehabilitation Engineering (2010)
- [8] Carol (Heins) Gonzales, Gony Leroy, and Gianluca De Leo Augmentative and Alternative Communication Technologies Claremont Graduate University, Claremont, CA, USA and Old Dominion University, Norfolk, Virginia, USA.
- [9] Howard P. Perette Jr, Southeast Missouri State University, Mary Jane Brotherson, Giving Families a Voice in Augmentative and alternative Communication Decision Making Iowa State University and Mary Blake Huer, California State University.
- [10] Stephanie Elizabeth Augmentative-alternative communication access for individuals with communication disorders in medical settings Amundsen Michigan State University, 2007.

