

# Power Quality Enhancement in Bridgeless Isolated Cuk Converter Fed BLDC Motor Drive

<sup>[1]</sup> Midhun Mathew John, <sup>[2]</sup> Phejil K Paul, <sup>[3]</sup> Liya Alias  
<sup>[1]</sup> PG Scholar, <sup>[2]</sup> Associate Professor, <sup>[3]</sup> Assistant Professor  
Mangalam College of Engineering, Ettumanoor, Kerala

---

**Abstract:--** In this a new bridgeless isolated power factor correction (PFC)-based Cuk converter-fed brushless dc (BLDC) motor drive is introduced for power factor correction and reduction in total harmonic distortion of input current. Dc link voltage of the voltage source inverter (VSI) feeding the BLDC motor is varied for speed control. This allows the operation of VSI in fundamental frequency switching to achieve an electronic commutation of the BLDC motor for reduced switching losses. A bridgeless configuration of an isolated Cuk converter is derived for the elimination of the front-end diode bridge rectifier to reduce conduction losses in it. The proposed PFC-based bridgeless isolated Cuk converter is designed to operate in discontinuous inductor current mode to achieve an inherent PFC at the ac mains. The proposed system is simulated in MATLAB using PI controller and implemented to achieve unity power factor at the ac mains. An improved power quality is also achieved at ac mains with power quality indices within the limits of international standards.

**Index Terms—** Power factor correction (PFC), Voltage Source Inverter (VSI), Discontinuous Inductor Conduction Mode (DICM).

---

## I. INTRODUCTION

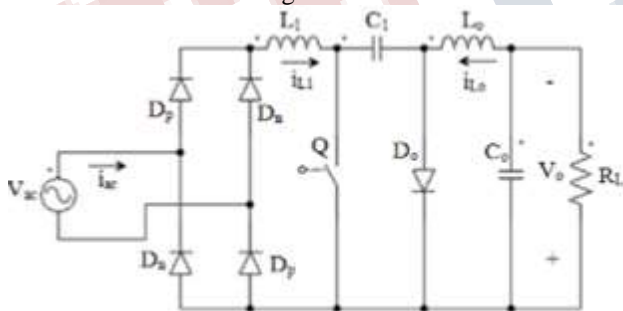
Brushless DC motors are being used extensively in multiple fields and is becoming popular due to its high efficiency, compact size, low maintenance, wide range of speed control and low electromagnetic interference. Because of these advantages it find its application in industrial tools, medical equipment's, precise motion control, automation and transportation. BLDC motor is basically a 3 phase synchronous motor consisting of concentrated 3 phase stator winding and permanent magnet rotor. A voltage source inverter is used for feeding the 3 phase stator winding. In conventional drive a diode bridge rectifier and dc link capacitor is used to supply voltage source inverter. This combination of diode bridge rectifier and high value dc link capacitor draws pulsating current from input having total harmonic distortion of the order 60-70% and power factor of the order 0.6-0.7. These power quality indices are unacceptable according to international power quality standards. To solve these problems improved power quality converters which are capable of improving power quality at input mains can be used.

An improved power quality converter should possess features of having well regulated output, isolation from input ac and output of the converter, sinusoidal input current with total harmonic distortion within the acceptable limits, and high efficiency. For this power factor correction

converters should operate in either continuous conduction mode or discontinuous conduction mode. Power factor correction converter operating in continuous conduction mode, uses current multiplier approach which offers low stress on switches but requires three sensors, one voltage sensor and two current sensors. Thus cost of these converters increase due to large sensing requirement. Power factor correction converters operating in discontinuous conduction mode using voltage follower approach requires a single voltage sensor. Thus cost of converter decreases but stress on switches increases. Thus the choice of operating mode depends on cost and permitted stress considerations. For low power applications power factor correction converters operating in discontinuous inductor current mode can be used as it require only one voltage sensor. In conventional boost converter fed BLDC motor presented in [2] uses PWM switching for voltage source inverter for speed control. This causes high switching losses in voltage source inverter and extra incurred cost of sensors. A SEPIC converter feeding BLDC motor is presented in [3], it is also based on PWM control, thus high switching losses across the switches due to high switching frequency. By using a concept of variable DC link voltage for speed control of BLDC reduces switching losses. This is achieved by operating the voltage source inverter in low frequency switching required for electronic commutation of the motor by the rotor positions sensed by a hall effect sensor.

Due to high efficiency bridgeless configurations of power factor correction converters are used. It eliminates front end diode bridge rectifier and associated losses in it. Bridgeless configuration of buck boost converter fed BLDC motor is presented in [4], it doesn't have isolation between input and output and high switching losses. In bridgeless single end primary inductor converter fed BLDC motor presented in [5], suffers from pulsating output due to pulsating discontinuous output current. These drawbacks will affect the entire efficiency of the system. A bridgeless configuration of cuk converter fed bldc motor is presented in [6], which is operated in continuous conduction mode and thus having the disadvantages of high cost due to increase in number of sensors required and also no isolation between input ac mains and output dc. As it is operated in continuous conduction mode it can be applied for high power application. Many bridgeless configurations using Sepic, Zeta and Luo converters are presented in [7-8].

Conventional power factor correction cuk converter is shown in the fig 1. It consist of diode bridge rectifier at the front end. During turn on of switch current conducts through two diodes in the bridge and power switch and during turn off current flows through the other two diodes in the bridge and power switch. Thus three devices conduct during turn on and turn off process resulting in conduction losses in it and heating of the switches. Thus bridgeless configuration of cuk converter is used for solving this.



**Fig. 1: conventional cuk converter**

Cuk converter has the advantages of high voltage conversion ratio, inherent power factor correction, easy implementation of transformer isolation and low electromagnetic interference. In this a bridgeless isolated cuk converter is used to feed the BLDC motor. Performance of the converter is simulated, implemented and analysed using PI controller.

## II. CIRCUIT CONFIGURATION OF PROPOSED SYSTEM

Fig. 2 shows the proposed power factor correction bridgeless isolated Cuk converter fed BLDC motor drive. A single-phase supply is used to feed a bridgeless isolated Cuk converter through an Lc filter. This bridgeless isolated cuk-converter, maintains the required dc link voltage of the voltage source inverter and is responsible for drawing sinusoidal input current and thus providing power factor correction at ac mains. The proposed power factor correction cuk converter is designed to operate in discontinuous inductor current mode to act as an inherent power factor corrector. Output inductor of cuk converter is made discontinuous for this. The speed control of BLDC motor is achieved by controlling the DC link voltage of voltage source inverter. The operation of voltage source inverter feeding the BLDC motor in low frequency switching enables electronic commutation of BLDC for reducing switching losses. This is achieved by rotor position sensed by hall effect sensor. The proposed system operated in voltage follower approach uses a single voltage sensor to control the dc link voltage for the speed control of the BLDC motor. The proposed drive is designed, and its performance is simulated for achieving an improved power quality at ac mains.

## III. OPERATION OF PROPOSED SYSTEM

The proposed power factor correction converter operation is classified into two ie, for positive and negative half cycles and switching cycle. Fig. 3 shows six different modes of operation.

### A. Operation during positive and negative half cycles of supply voltage

Fig. 3(a)–(c) and (d)–(f) shows the operation of the power factor correction bridgeless cuk converter for positive and negative half cycles of supply voltage, respectively. The proposed bridgeless isolated Cuk converter is having two power switches Sw1 and Sw2, such that switch Sw1 conducts for positive half cycle and switch Sw2 conduct for negative half cycle of supply voltage. Switch Sw1, input and output inductors, intermediate capacitors C11 and C21, and diodes D1 and Dp are in the state of conduction during the positive half cycle of line voltage and Switch Sw2, input and output inductors, intermediate capacitors C21 and C22, and diodes D2 and Dp are in the state of conduction during the negative

**International Journal of Engineering Research in Electrical and Electronic Engineering (IJEREEE)**  
Vol 2, Issue 8, August 2016

half cycle of line voltage as shown in Fig. 3(a)–(f). hence six components and a power switch conducts for a single half cycle of line voltage. The proposed power factor correction bridgeless cuk converter operates in three different modes during the positive and negative half cycles of the line voltage. The current of output inductors  $L_{o1}$  and  $L_{o2}$  become discontinuous in a switching period during discontinuous inductor current mode. However, the current flowing in the input inductors and magnetizing inductance of the high frequency transformer and the voltage across the intermediate capacitor remain continuous in a complete switching period.

**B. Operation during positive and negative half cycles of supply voltage**

Fig. 3(a)–(c) shows three modes of operation of a bridgeless isolated cuk converter in a switching period for the positive half cycle of supply voltage. Fig. 4 shows its associated waveforms in DICM ( $L_o$ ) mode of operation as follows.

**1) Mode I :**

In this mode, when the switch  $Sw_1$  is turned on, the input inductor  $L_{i1}$  charges and intermediate capacitor  $C_{11}$  discharges through switch  $SW_1$  and magnetizing inductance of high frequency transformer and it starts charging as shown in Fig. 3(a). The input side intermediate capacitor  $C_{11}$  supplies the energy to the high frequency transformer and according to the dot convention, the output side intermediate capacitor  $C_{21}$  discharges and supplies the required energy to the dc link capacitor and during this time output inductor get charged as shown in Fig. 3.

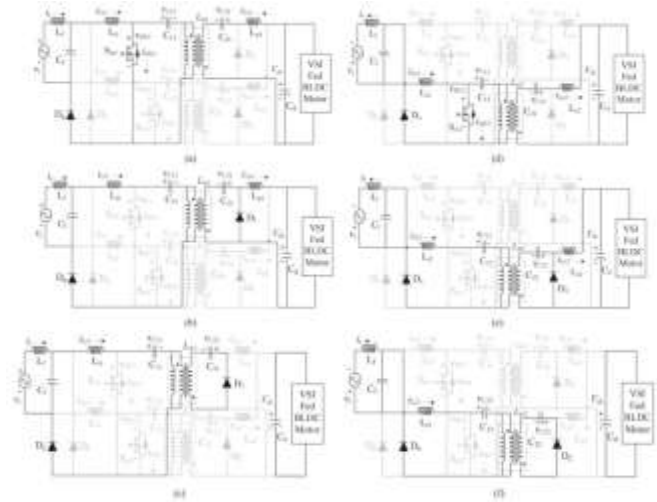
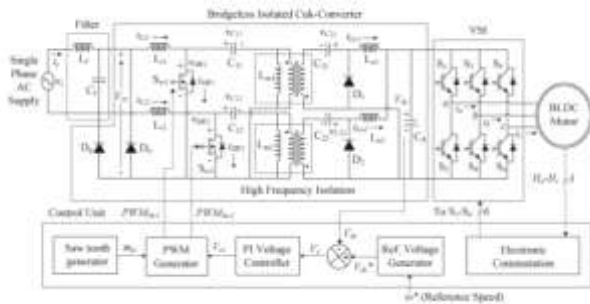


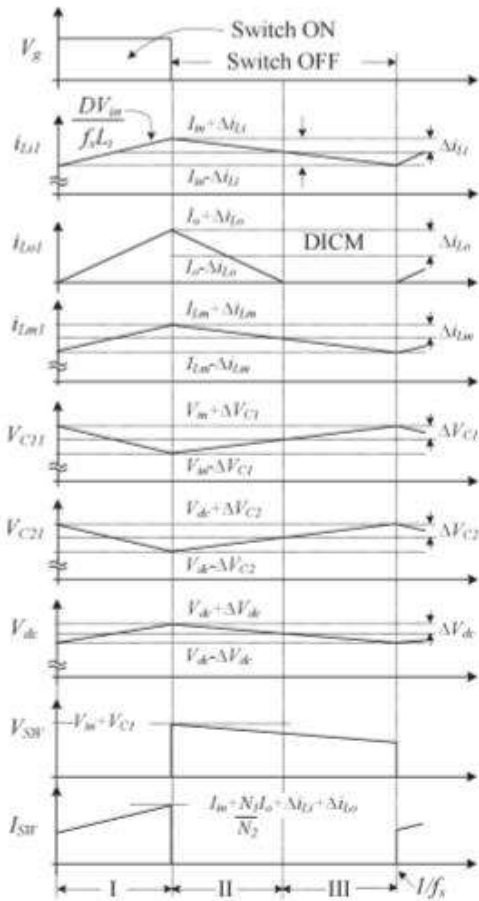
Fig 3-Modes of operation of cuk converter fed BLDC motor

**2) Mode II :**

When the switch  $Sw_1$  is turned off, the input inductor  $L_{i1}$  discharges, input intermediate capacitor charges and magnetizing inductance of high frequency transformer in the polarity as shown in Fig. 3(b) start discharging. According to dot convention the output intermediate capacitor charges through the diode and the output inductor discharges through dc link capacitor and diode supplying energy to dc link capacitor which in turn discharges and feed the load.

**3) Mode III :**

During this interval, the output inductor get completely discharged that enables discontinuous inductor current mode ie, the current  $I_{Lo1}$  becomes zero. Input inductor  $L_{i1}$  and magnetizing inductance of high frequency transformer  $L_{m1}$  continue to discharge as shown in Fig. 2(c). The output side intermediate capacitor  $C_{21}$  continues to charge and the dc link capacitor  $C_d$  supplies the required energy to the BLDC motor as shown in Fig. 4.



**Fig. 4: Waveforms in one switching cycle.**

Similarly the operation for the negative half cycle of the supply voltage is realized. Initially, the intermediate capacitors C11, C12, C21, and C22 are completely discharged and are charged during the operation of the PFC converter. The voltage across the input side intermediate capacitors (C11 and C12) depends upon the instantaneous input voltage; hence, the initial charging of C11 and C12 is zero. However, the output side intermediate capacitors (C21 and C22) are not completely discharged in a switching period or a half line cycle of the supply voltage due to the voltage maintained at the dc link capacitor (Cd). Moreover, during the operation of the PFC converter in the positive half cycle, the energy storage components on the primary side of the high frequency transformer remain in non-conducting state and are completely discharged. However, the energy storage components on the secondary side of high frequency

transformer remain charged at its full voltage due to the unavailability of a discharging path and the presence of the dc link capacitor (Cd).

**IV. DESIGN OF PROPOSED SYSTEM**

Bridgeless power factor correction converter is designed to operate in discontinuous inductor current mode. Instantaneous input current is given by

$$V_{in}(t) = V_m \sin(\omega t) \dots\dots\dots(1)$$

The output voltage *Vdc* of a bridgeless isolated Cuk converter is given by

$$V_{dc} = (N_2 N_1) (D1 - D) \dots\dots\dots(2)$$

Substituting eqn (1) in (2) implies we get instantaneous duty ratio as

$$D(t) = V_{dc} (N_2 N_1) V_{in}(t) = V_{dc} (N_2 N_1) V_m \sin(\omega t) + V_{dc} \dots\dots\dots(3)$$

For getting dc link voltage as 130V, the instantaneous duty ratio should be 0.53. Instantaneous power is given by

$$P_i = (P_{max} V_{dcmax}) V_{dc} \dots\dots\dots(4)$$

The input inductor value operating in continuous conduction mode is given by

$$L_{i1,2} = V_{in}(t) D(t) / \Delta i_{in}(t) f_s = (1/f_s) (V_s^2 P_i) / (V_{dc} V_{in}(t) + V_{dc}) \dots\dots\dots(5)$$

$$= 1 / 0.5 * 20000 (230 * 230 / 250) (0.53) = 10.5 \text{ mH}$$

The value of input inductor is taken as 10mH where fs is 20Khz. The critical value output inductor operating in discontinuous mode is given by

$$L_{oc} = (V_s^2 P_i) / (V_{dc} 2 V_{in}(t) f_s) (V_{dc} V_{in}(t) + V_{dc})$$

For minimum dc link voltage of 50V the critical value of output inductor is obtained as 0.353mH and for maximum dc link voltage of 130V critical value is obtained as 1.4mH. For discontinuous conduction the value of output inductor is selected a value lower than the critical value got for minimum dc link voltage. Thus 0.2mH is taken as the

**International Journal of Engineering Research in Electrical and Electronic  
Engineering (IJEREE)**  
Vol 2, Issue 8, August 2016

value of output inductors. The value of input intermediate capacitor for continuous conduction mode is given by

$$C_{11,12} = \frac{V_{in} \cdot I_{L1} \cdot D(t)}{2 \Delta V_{C1}(t) \cdot f_s \cdot R_L (1-D(t))} \\ = \frac{P_i \cdot K \cdot \sqrt{2} V_s(t) \cdot f_s (\sqrt{2} V_s + V_{dc})}{\Delta V_{C1}(t)}$$

After calculation the value of input intermediate capacitor is obtained as 363.7nF and is taken as 330nF. The value of output intermediate capacitor operating in continuous conduction is given by

$$C_{21,22} = \frac{V_{dc} \cdot I_{L2} \cdot D(t)}{\Delta V_{C2}(t) \cdot f_s \cdot R_L} \\ = \frac{P_o \cdot X \cdot V_{dc} \cdot f_s (\sqrt{2} V_s + V_{dc})}{\Delta V_{C2}(t)}$$

the output side intermediate capacitors (C21 and C22) are of 4.4 μF.

### V. SIMULATION RESULTS

The first section describes the software implementation of the open-loop control system of the proposed converter topology-Integrated dual output converter. The second section gives the simulation results of the system with closed loop control system. The next section explains the comparison between the results of open loop and closed loop control outputs of the proposed system.

#### A. Simulation Results of the Proposed System using PI controller.

The proposed system is simulated using PI controller in MATLAB/SIMULINK R2013a. Design parameters are shown in the table below..

Sl.No.	Parameters	specifications
1.	Input Voltage, $V_{in}$	230V
2.	Dc link voltage, $V_{dc}$	130V
3.	Switching frequency, $f_s$	20Khz
4.	Input inductor, $L_{i1}, L_{i2}$	10mH
5.	Output inductor, $L_{o1}, L_{o2}$	0.2mH
6.	Input intermediate capacitor	330nf
7.	Output intermediate capacitor	4.4uf

The proposed drive system speed, input current, power factor and total harmonic distortion when input voltage is 220V and for DC link voltage 130V using PI controller are as below.

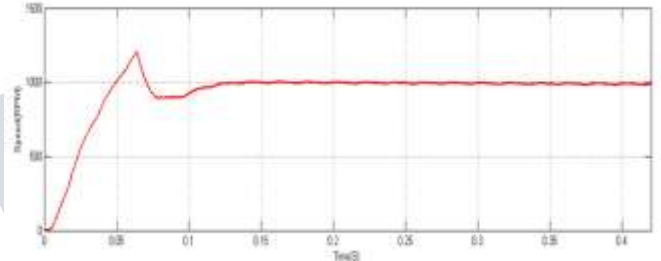


Fig. 5. Speed of motor.

The speed of motor is about 1000 RPM here. Input current of the system using PI controller is shown in fig.6.

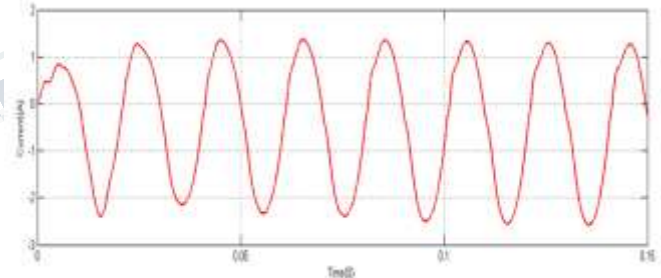


Fig. 6. Input current.

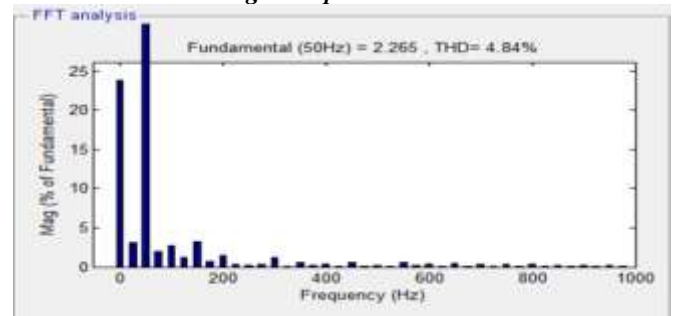
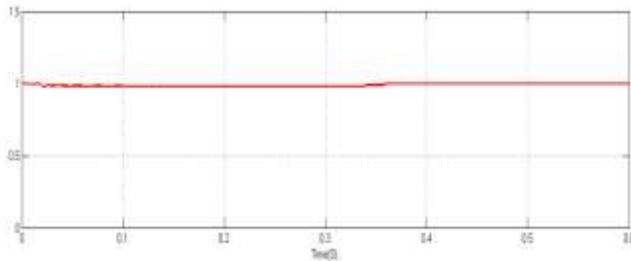


Fig. 7. THD of input current.

**TABLE I**  
**PARAMETER SPECIFICATION OF THE PROPOSED SYSTEM**

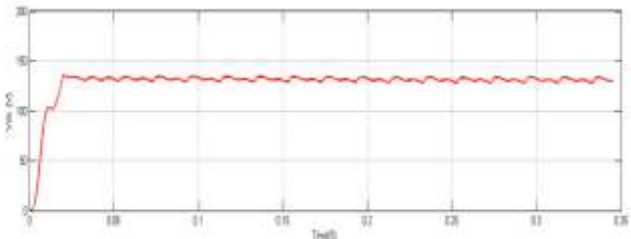


**Fig. 8. Power factor waveform**

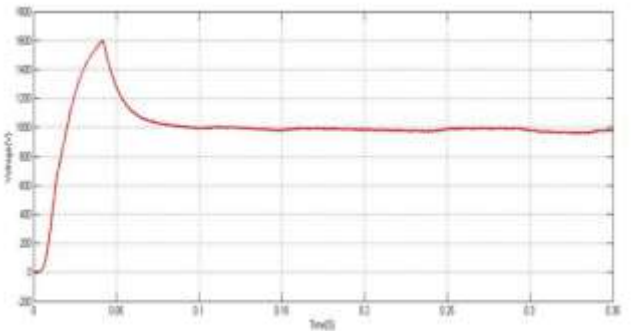
Total harmonic distortion of input current is shown in fig7. Power factor of proposed system is shown in fig 8. Power factor obtained by using PI controller is almost unity.

**B. Simulation Results of the BL luo converter fed drive System using PI controller.**

The BL luo converter fed drive systems DC link voltage, speed, input current, power factor and total harmonic distortion when input voltage is 220V and for DC link voltage 130V using PI controller are as below. Dc link voltage of BL luo converter fed BLDC motor drive system is shown in fig.9

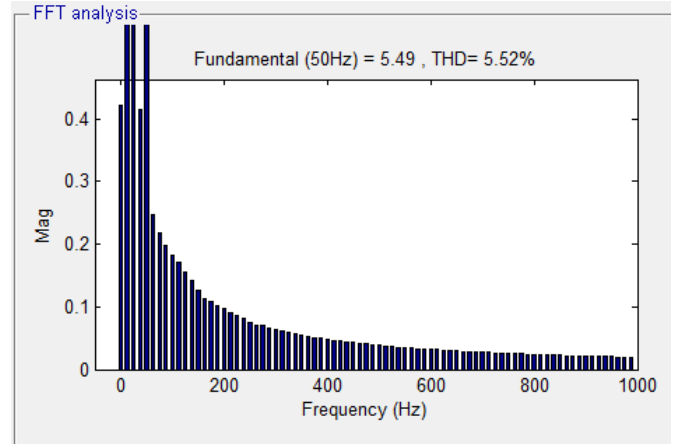


**Fig. 9. DC link voltage.**



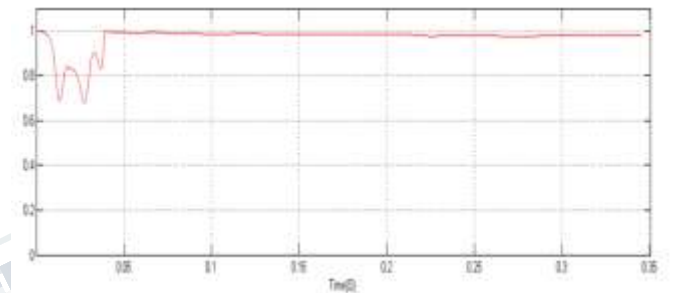
**Fig. 10. Speed of motor.**

Speed of motor is given in fig.10. The speed of motor is about 1000 RPM here.



**Fig. 11. THD of input current.**

THD of input current is obtained as 5.52% which is shown in fig.11. Power factor of this system is shown in fig.12. It is about 0.98.



**Fig. 12. Power factor waveform**

**VI. COMPARISON OF RESULTS**

Sl. No.	Topologies	Vs (V)	Vdc (V)	Speed (RPM)	Thd (%)	Pf
1.	BL Cuk converter using PI controller	220	130	990	4.84	0.99
2.	BL Luo converter using PI controller	220	130	990	5.52	0.98

**VII. CONCLUSION**

**International Journal of Engineering Research in Electrical and Electronic  
Engineering (IJEREEE)  
Vol 2, Issue 8, August 2016**

---

A bridgeless isolated cuk converter fed BLDC motor for low power application has been proposed. Speed control is achieved by controlling the dc link voltage of VSI. This bridgeless configuration is designed such that the conduction losses in front-end converter is reduced by eliminating DBR. For dc link voltage control the proposed converter is operated in DICM and inherent PFC is achieved at ac mains. Total harmonic distortion in input current has been reduced. Satisfactory test results for the proposed bridgeless isolated Cuk converter-fed BLDC motor in simulations using PI controller. The proposed converter is being compared with BL luo converter drive system for THD and power factor.

[7] B. Singh et al., "A review of single-phase improved power quality acdc converters," IEEE Trans. Ind. Electron., vol. 50, no. 5, pp. 962–981, Oct. 2003

#### REFERENCES

[1] V. Bist and B. Singh, "A Unity Power Factor Bridgeless Isolated Cuk Converter-Fed Brushless DC Motor Drive" Proc. IEEE, vol. 97, no. 11, pp. 1773–1789, Jul. 2015.

[2] T. Gopalarathnam and H. A. Toliyat, "A new topology for unipolar brushless dc motor drive with high powerfactor," IEEE Trans. Power Electron., vol. 18, no. 6, pp. 1397–1404, Nov. 2003.

[3] A. Barkley, D. Michaud, E. Santi, A. Monti, and D. Patterson, "Single stage brushless dc motor drive with high input powerfactor for single phase applications," in Proc. 37th IEEE PESC, Jun. 18–22, 2006

[4] V. Bist and B. Singh, "An adjustable speed PFC bridgeless buck-boost converter fed BLDC motor drive," IEEE Tran. Ind. Electron., vol. 61, no. 6, pp. 2665–2677, Jun. 2014

[5] V. Bist and B. Singh, "A reduced sensor PFC BL-Zeta converter based VSI fed BLDC motor drive," Elect. Power Syst. Res., vol. 98, pp. 11–18, May 2013.

[6] V. Bist and B. Singh, "PFC Cuk converter fed BLDC motor drive," IEEE Trans. Power Electron., vol. 30, no. 2, pp. 871–887, Feb. 2015.