

# Performance of a 4- Switch, 3-Phase Inverter Fed Induction Motor (IM) Drive System

Nagesh Patwari  
Student,

Department of Electrical Engineering,  
Government College of Engineering, Aurangabad

**Abstract:**— This project proposes the performance of a 4- switch, 3-phase inverter fed induction motor (IM) drive system for high performance industrial drive systems. In the proposed realization, instead of a usual 6-switch three-phase inverter (SSTPI) a 4-switch three-phase inverter (FSTPI) is used. A cost effective FSTPI fed IM drive using Field-Oriented-Control and Space-Vector PWM controller (with new control SVPWM approach) is implemented in real time. This reduces the cost of the inverter, the switching losses, and the complexity of the control algorithms and interface circuits to generate 6 PWM logic signals. Furthermore, the proposed control approach reduces the computation for real-time implementation. In this paper, a simulation model of the drive system is developed and analyzed in order to verify the effectiveness of the approach. The complete vector control scheme for the IM drive fed from the proposed 4S3P inverter is implemented in real-time using digital signal processor for a prototype 1 hp motor. Theoretical and experimental results of the proposed drive verify the robustness of the drive. A performance comparison of the proposed IS3P inverter fed drive with a conventional 6S3P inverter fed drive is also made in terms of speed response and total harmonic distortion (THD) of the stator current. Simulation results show that the proposed drive system provides a fast speed response and good disturbance rejection capability. The designed inverter fed IM drive is found suitable considering its cost decrease and the robustness.

**Index Terms:**—State FPGA-Field Programmable Gate Array, FSTPI- Four Switch Three Phase Inverter, IM-Induction Motor, PWM-Pulse Width Modulation, THD-Total Harmonic Distortion..

## I. INTRODUCTION

Over the year's induction motor (IM) has been utilized as a workhorse in the industry due to its easy build, high robustness, and generally satisfactory efficiency. By tradition, 6-switch 3-phase inverters have been widely used for variable speed IM drives. The last work on FSTPI for IM drives investigated the performance of a 4-switch, 3-phase inverter fed cost effective induction motor in real time, which has been implemented by vector control. A standard three-phase voltage source inverter utilizes three legs [six-switch three-phase voltage source inverter, with a pair of complementary power switches per phase. The FSTPI structure generates four active vectors in the plane, instead of six, as generated by the sstpi topology. A reduced switch count voltage source inverter [four switch three-phase voltage source inverter uses only two legs, with four switches. Several articles report on fstpi structure regarding inverter performance and switch control. This paper presents a general method to generate pulse width modulated (pwm) signals for control of four-switch, three phase voltage source inverters, even when there are voltage oscillations across the two dc-link capacitors. The method is based on the so called space vector modulation, and

includes the scalar version. This permits to implement all alternatives, thus allowing for a fair comparison of the different modulation techniques. The proposed method provides a simple way to select either three, or four vectors to synthesize the desired output voltage during the switching period. In the proposed approach, the selection between three or four vectors is parameterized by a single variable. The influence of different switching patterns on output voltage symmetry, current waveform, switching frequency and common mode voltage is examined. The paper also discusses how the use of the wye and delta connections of the motor windings affects the implementation of the pulse width modulator.

## II. PROPOSED TECHNOLOGY

The block diagram of the proposed system is shown in Fig.1. The drive system consists of a 3 phase AC supply, 3 phase Diode bridge Rectifier, 3 phase four switch Inverter, 3-phase Induction Motor and controlled circuits. The standard AC power supply is converted to a DC by using a 3-phase diode bridge rectifier. A voltage source FSTPI is used to convert the DC voltage to the controlled AC voltage. The output of FSTPI is fed to 3-phase induction motor. VHDL program is used in Xilinx software to generate the controlled PWM pulses at

different duty ratio for FSTPI to drive the Induction Motor at different speeds.

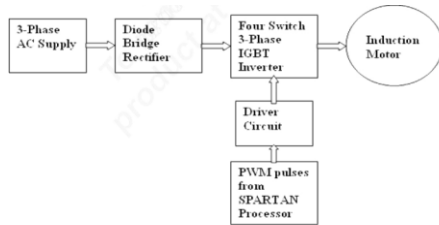
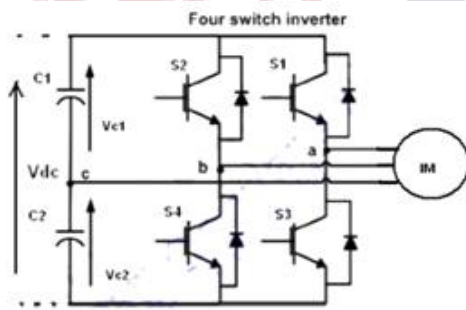

Fig (1.)

Block diagram of computational scheme

**FSTPI**

The power circuit of the FSTPI fed Induction Motor drive is shown in Fig. 2. The power inverter has 4 switches, S1, S2, S3 and S4 and a split capacitor. The two phases ‘a’ and ‘b’ are connected to the two legs of the inverter, while the third phase ‘c’ is connected to the centre point of dc link capacitors, C1 and C2. The value of the capacitances C1 and C2 are equal.  $V_{c1}$  and  $V_{c2}$  are the voltage across the DC link capacitors ( $V_{c1}=V_{c2}$ ). ‘Vdc’ is the voltage across the capacitor C1 and C2 ( $V_{dc}=V_{c1}+V_{c2}$ ).



Fig(2.) FSTPI with Induction Motor

**III. PWM GENERATION IN TWO-LEG INVERTER USING XILINX FPGA**

PWM signals are generated from the Spartan-3 processor by writing VHDL program to control these 4 switches. The phase voltage is determined by the duty cycle of the PWM signals. The switching signal parameters namely switching frequency, the duty ratio and the number of pulses are easily controlled via VHDL programming language. The timing of PWM pulses are generated by using

equations. A small dead-time is given between switching off the upper switch and switching on the lower switch and vice versa. This ensures that both switches are not conducting when they change states from on to off, or vice versa. For the induction motor drive, the three phase voltage references in a balanced set are given by equation.

$$V_{as}^* = V_m \cos \omega t n.$$

$$V_{bs}^* = V_m \cos \left( \omega t - \frac{2\pi}{3} \right)$$

$$V_{cs}^* = V_m \cos \left( \omega t + \frac{2\pi}{3} \right)$$

$$V_{ac}^* = V_{as}^* - V_{cs}^* = \sqrt{3} V_m \cos \left( \omega t - \frac{\pi}{6} \right)$$

$$V_{bc}^* = V_{bs}^* - V_{cs}^* = \sqrt{3} V_m \cos \left( \omega t - \frac{\pi}{2} \right)$$

$$T_1 = \frac{T_s}{2} + \frac{V_{ac}^*}{V_{dc}} T_s$$

$$T_2 = \frac{T_s}{2} + \frac{V_{bc}^*}{V_{dc}} T_s$$

In this paper the scalar modulation scheme is adopted since it is simple and easy. The scalar modulation uses the phase voltages in calculating the switching time. Since the two phases of the induction motor are connected to the inverter legs and the third phase is connected to the neutral point of the dc link, the line-to-line voltage can be used for the PWM instead of the phase voltage. The c phase is connected to the neutral point. From Eqns. the two line-to-line voltage references are given by a Novel Implementation of Xilinx FPGA Based Four Switch Three Phase IGBT Inverter Fed Induction Motor Drive Using PWM.

**V. SIMULATION WORK AND RESULTS**

Digital computer simulation model of FSTPI fed induction motor drive has been developed by using SIMULINK/MATLAB. The simulation work has been performed for this drive system at different load conditions. Weighted total harmonic distortion (THD) has been used to evaluate the performance of the FSTPI with load and without load conditions in this simulation work. This FSTPI fed drive system consists of a three-phase diode bridge rectifier, a split capacitor, four switch three phase inverter and 3-phase squirrel cage Induction Motor. Input supply voltage: 3-phase, 415 V (rms), 50 Hz; Induction Motor: 5 hp 415 V, 50 Hz, 1430 rpm. The complete simulink block diagram of system is shown in Fig. This block diagram consists of 2 blocks. Switching pulses block generates the PWM pulses for 4-switches of FSTPI at the terminals Out1 to Out4 and FSTPI with IM block contains Diode bridge rectifier,

FSTPI and IM. Vabc and Iabcblock is used to display the 3-phase voltage and current waveforms. The Simulation circuit diagram of the drive system is shown in Fig. This circuit contains 3-phase input AC power supply, diode bridge rectifier, split capacitor, 4-IGBT switches and 3-phase 3hp IM.

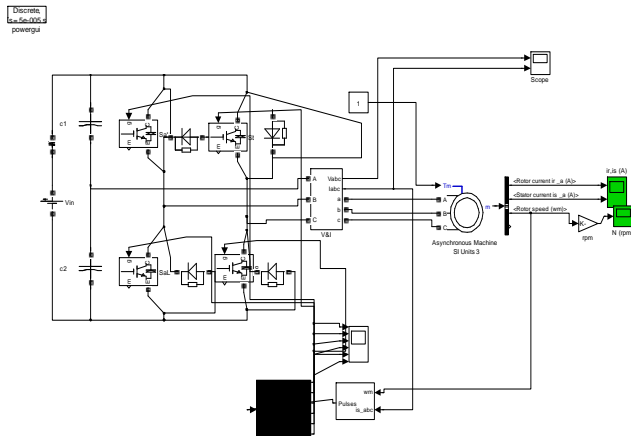

Fig (3.) Simulink diagram

The 3-phase output currents of FSTPI  $i_a$ ,  $i_b$  and  $i_c$  with IM are shown in Fig.7. The output line voltage waveform  $V_{ab}$  of FSTPI is shown in Fig. The speed and torque characteristics of induction motor with and without load are shown. It is observed that the speed increases linearly and reaches the rated speed (1430 rpm) at steady state in 0.75 sec. At starting the torque increases and reduces to a minimum value when the speed reaches the rated value. In Fig.7 the same torque and speed curve is shown with full load at 10 N-m. The Total Harmonic Distortion (THD) with load and without load conditions is shown in Fig.11 and Fig.12. It is found that THD without load is 9.32% and with load is 8.24%.

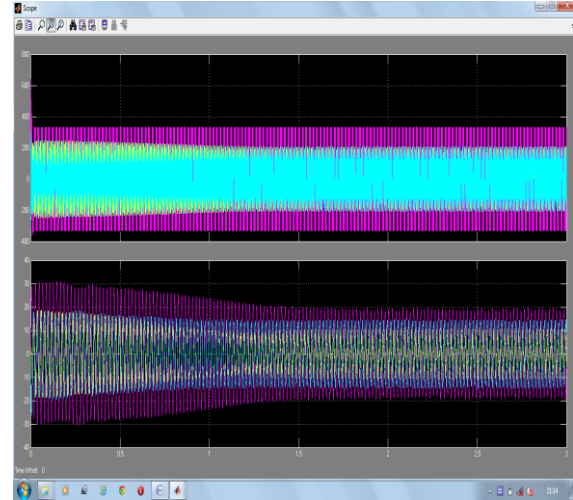

Fig (4.) Stator & Rotor current

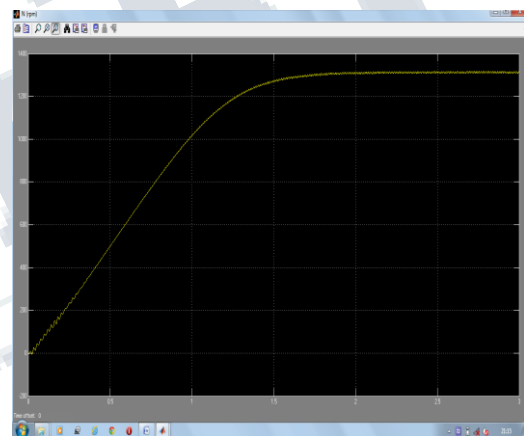
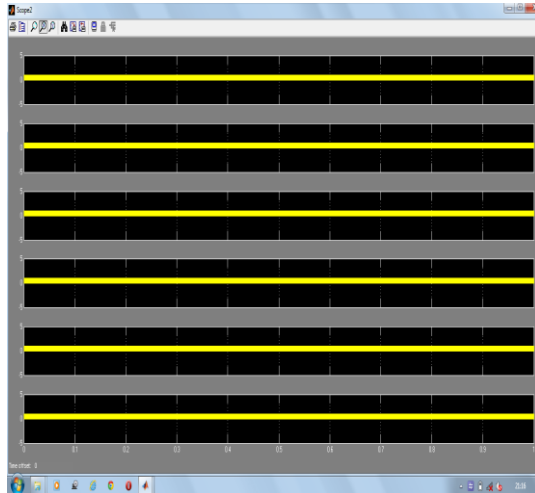
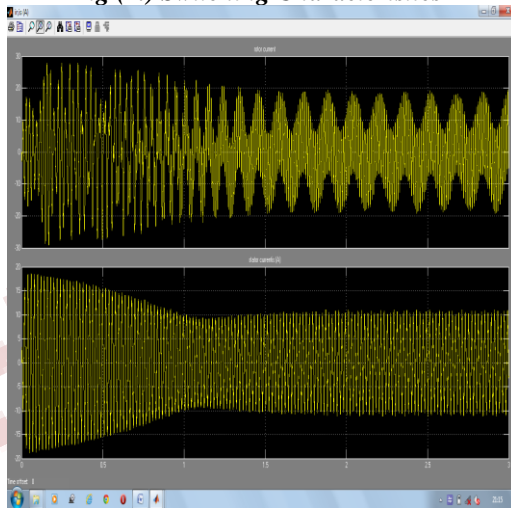

Fig (5.) Speed characteristics



**Fig (7.) Switching Characteristics**



**Fig( 7.)Torque Characteristics**

## VI. CONCLUSION

A cost effective FSTP inverter fed PMSM drive has been simulated and successfully implemented. This paper presents a complete model development and analysis for four switch three phase inverter fed synchronous reluctance motor drive. The results obtained and presented in this work indicate that the proposed control scheme produces very fast response of the SynRM drive. A comparison of performances for the proposed FSTP inverter fed SynRM drive with conventional SSTP inverter fed

drive has also been made in terms of speed response, torque response, and three phase currents under identical operating conditions. The drive also shows good performance in speed operation under the effect of load disturbances, parameter variation, and reversal of speed. The proposed control scheme with low cost implementation is suitable for commercial applications. An FPGA based implementation of FSTPI fed IM drive using PWM control is successfully carried out in simulation and real-time experiment. MATLAB SIMULINK is used for simulation and the hardware. Implementation is carried out using SPARTAN-3 processor. VHDL (Very high speed description language) program is developed in XILINX to generate the controlled PWM pulses to drive the system. A Implementation of Xilinx FPGA Based Four Switch, three Phase IGBT Inverter Fed Induction Motor Drive Using PWM 433. The proposed FSTP inverter fed PMSM drive is found acceptable considering its cost reduction and other advantageous features.

## VII. ACKNOWLEDGMENT

We take this opportunity to express our deepest gratitude and appreciation to all those who have helped us directly or indirectly towards the successful completion of this paper.

## REFERENCES

- 1) Bose B.K., Power Electronics and AC Drives, Englewood Cliffs, NJ: Prentice Hall, 1986
- 2) Frede Blaabjerg,, Sigurdur Freysson, Hans-Henrik Hansen, and S. Hansen "A New Optimized Space-Vector Modulation Strategy for a Component-Minimized Voltage Source Inverter" *IEEE Trans. on Power Electronics*, Vol. 12, No. 4, July 1997, pp 704-710.
- 3) Jaehong Kim, Jinseok Hong, and Kwanghee Nam, "A Current Distortion Compensation Scheme for Four-Switch Inverters," *IEEE Trans. Power Electronics*, vol. 24, no. 4, pp. 1032- 1040, April 2009.
- 4) Maurício Beltrao de Rossiter Correa and Cursino Brandão Jacobina, "A General PWM Strategy for Four-Switch Three-Phase Inverters," *IEEE Transactions on Power Electronics*, vol. 21, no. 6, pp.1618-1627, November 2006.

- 5) M. N. Uddin, T. S. Radwan, and M. A. Rahman, "Fuzzy-logic-controller-based cost-effective four-switch three-phase inverter-fed PM synchronous motor drive system," *IEEE Trans. Ind. Appl.*, vol. 42, no.1, pp. 21–30, Jan./Feb. 2006.
- 6) C. T. Lin, C. W. Hung, and C. W. Liu, "Position sensorless control for four-switch three-phase brushless DC motor drives," *IEEE Tran. Power Electronics*, vol. 23, no. 1, pp. 438–444, Jan. 2008.

#### **BIOGRAPHY**

Mr.Nagesh Patwari, Student, S.B.Patil College of engineering, Indapur.

