

Enhancement of Power Quality by Using D-Statcom

^[1] Mr. S.S.Godhade ^[2] Mr.Amanulla Naikwade ^[3] Miss.Archana Chavan ^[4] Mr.Swapnil Gaikwad Drives
^[5] Miss.Supriya Patsupe, ^[6] Mr.Shivpratap Patil
Electrical Engg.Department

^[1, 2, 3, 4, 5, 6] Sanjay Ghodawat Group of Institutions, Atigre, Kolhapur, Maharashtra, India

Abstract— there are different ways to improve power quality problems in electrical power system. Among these the D-STATCOM is one of the most effective devices. A pulse width modulation scheme has been implemented to control the gates circuit of the D-STATCOM Controller. To improve the quality of power, active power filters have been proposed. The distribution static compensator (DSTATCOM) is a shunt active filter, which injects currents into the point of common coupling (PCC) (the common point where load, source, and DSTATCOM are connected) such that the harmonic filtering, power factor correction, and load balancing can be achieved. The DSTATCOM filters load current such that it meets the specifications for utility connection.

Key words—Power quality, PCC, PWM, D-STATCOM components.

I. INTRODUCTION

The majority of power consumption has been drawn in reactive loads such as pumps, electric motors, electric welding etc. These loads draw lagging power-factor currents and therefore give rise to reactive power burden in the distribution system. The excessive reactive power demand increases feeder losses and reduces the active power flow capability of system where as unbalancing affects the operation of transformers and generators. Reactive power plays a vital role on the stability of power system. Therefore, the reactive power compensation is necessary in the power systems. The Harmonic currents in distribution system can causes harmonic distortion, Low power factor and also causes heating in electrical equipment. It also can causes vibration and noise in machines and so the damaging of sensitive machine parts.

There are different ways to improve power quality problems in electrical power system. Among these the D-STATCOM is one of the most effective devices. A pulse width modulation scheme has been implemented to control the gates circuit of the D-STATCOM Controller. To improve the quality of power, active power filters have been proposed. The distribution static compensator (D-STATCOM) is a shunt active filter, which injects currents into the point of common coupling (PCC) (the common point where load, source, and D-STATCOM are connected) such that the harmonic filtering, power factor correction, and load balancing can be achieved. In practice, the load is remote from the distribution substation and is associated with feeder impedance. In the presence of feeder impedance,

the inverter switching distorts both the PCC voltage and the source currents. In this situation, the source is termed as non stiff.

The D-STATCOM filters load current such that it meets the specifications for utility connection. If properly utilized, this device can cancel

- The effect of poor load power factor such that the current drawn from the source has a near unity power factor;
- The effect of harmonic contents in loads such that current drawn from the source is sinusoidal.

II. LITERATURE REVIEW

Static Synchronous Compensator (STATCOM)

STATCOM is one of the key FACTS Controllers. It can be based on a voltage sourced or current-sourced converter. As mentioned before, from an overall cost point of view, the voltage-sourced converters seem to be preferred, and will be the basis for presentations of most converter-based FACTS Controllers. For the voltage-sourced converter, its ac output voltage is controlled such that it is just right for the required reactive current flow for any ac bus voltage dc capacity or voltage is automatically adjusted as required to serve as a voltage source for the converter. STATCOM can be designed to also act as an active filter to absorb system harmonics.

Distributed Static Compensator (Dstatcom)

The Distribution Static Compensator (DSTATCOM) is a voltage source inverter based static compensator (similar in many respects to the DVR) that is used for the correction of bus voltage sags. Connection (shunt) to the distribution network is via a standard power

distribution transformer. The DSTATCOM is capable of generating continuously variable inductive or capacitive shunt compensation at a level up its maximum MVA rating. The DSTATCOM continuously checks the line waveform with respect to a reference ac signal, and therefore, it can provide the correct amount of leading or lagging reactive current compensation to reduce the amount of voltage fluctuations. The major components of a DSTATCOM are shown in Fig. 2. It consists of a dc capacitor, one or more inverter modules, an ac filter, a transformer to match the inverter output to the line voltage, and a PWM control strategy. In this DSTATCOM implementation, a voltage-source inverter converts a dc voltage into a three-phase ac voltage that is synchronized with, and connected to, the ac line through a small tie reactor and capacitor (ac filter).

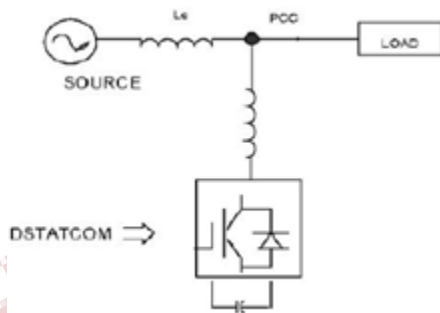

Fig.1. Block diagram DSTATCOM circuit.

DSTATCOM components:

DSTATCOM mainly involves three parts

• **IGBT or MOSFET based dc-to-ac inverters:**

These inverters are used which create an output voltage wave that's controlled in magnitude and phase angle to produce either leading or lagging reactive current, depending on the compensation required.

• **L-C filter:**

The LC filter is used which reduces harmonics and matches inverter output impedance to enable multiple parallel inverters to share current. The LC filter is chosen in accordance with the type of the system and the harmonics present at the output of the inverter.

• **Control block:**

Control block is used which switch Pure Wave DSTATCOM modules as required. They can control

external devices such as mechanically switched capacitor banks too. These control blocks are designed based on the various control theories and algorithms like instantaneous PQ theory, synchronous frame theory etc.

III. BASIC OPERATING PRINCIPLE

Basic operating principle of a DSATCOM is similar to that of synchronous machine. The synchronous machine will provide lagging current when under excited and leading current when over excited. DSTATCOM can generate and absorb reactive power similar to that of synchronous machine and it can also exchange real power if provided with an external device DC source.

1) Exchange of reactive power:- if the output voltage of the voltage source converter is greater than the system voltage then the DSATCOM will act as capacitor and generate reactive power(i.e.. provide lagging current to the system)

2) Exchange of real power: as the switching devices are not loss less there is a need for the DC capacitor to provide the required real power to the switches. Hence there is a need for real power exchange with an AC system to make the capacitor voltage constant in case of direct voltage control. There is also a real power exchange with the AC system if DSTATCOM id provided with an external DC source to regulate the voltage in case of very low voltage in the distribution system or in case of faults. And if the VSC output voltage leads the system voltage then the real power from the capacitor or the DC source will be supplied to the AC system to regulate the system voltage to the =1p.u or to make the capacitor voltage constant.

Hence the exchange of real power and reactive power of the voltage source converter with AC system is the major required phenomenon for the regulation in the transmission as well as in the distribution system. For reactive power compensation, DSTATCOM provides reactive power as needed by the load and therefore the source current remains at unity power factor (UPF). Since only real power is being supplied by the source, load balancing is achieved by making the source reference current balanced. The reference source current used to decide the switching of the DSTATCOM has real fundamental frequency component of the load current which is being extracted by these techniques.

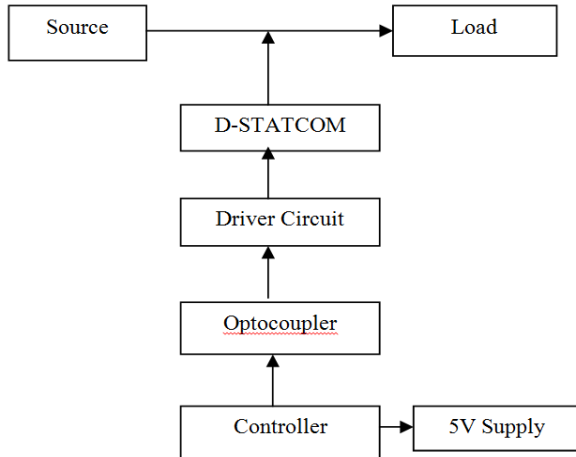

Fig.2. Block Diagram of Proposed System

IV. CONTROL STRATEGY

SINUSODAL PWM:

Sinusoidal PWM technique is used which is simple and gives a good response. The error signal obtained by comparing the measured system RMS voltage and there reference voltage, is fed to a PI controller which generates the angle which decides the necessary phase shift between the output voltage of the VSC and the AC terminal voltage. This angle is summed with the phase angle of the balanced supply voltages, assumed to be equally spaced at 120 degrees, to produce the desired synchronizing signal required to operate the PWM generator.

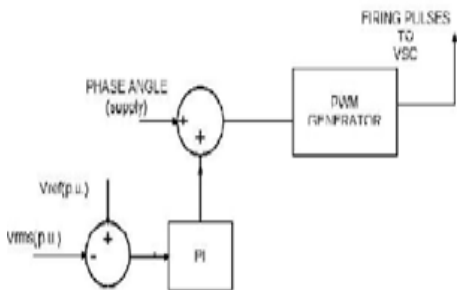

Fig.3. SPWM Control

V. SIMULATION

Simulation without D-STATCOM compensation:

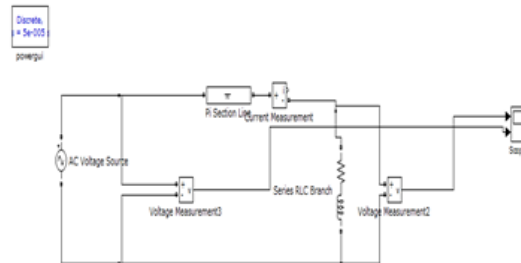

Fig. 4. Simulation without DSTATCOM

Here for the study purpose we consider a small prototype system, considering one 230V, 50KM Pi section line. Pi section line shows transmission line parameters, resistance, inductance , capacitance.

Simulation With D-STATCOM Compensation:

In this work, the performance of VSC based power devices acting as a voltage controller is investigated. Moreover, it is assumed that the converter is directly controlled for this it requires measurement of the RMS voltage and current at the load point. The DSTATCOM is commonly used for voltage Ssags mitigation and harmonic elimination at the point of connection.

The DSTATCOM employs the same blocks as the DVR, but in this application the coupling transformer is connected in shunt with the ac system, as illustrated in Fig.5 which is controllable in phase and magnitude. These currents are injected into the ac distribution system in order to maintain the load voltage at the desired voltage reference. Active and reactive power exchanges between the VSC connected in shunt with the ac system provides a multifunctional topology which can be used for up to three Quite distinct purposes:

- 1) Voltage regulation and compensation of reactive power;
- 2) Correction of power factor
- 3) Elimination of current harmonics

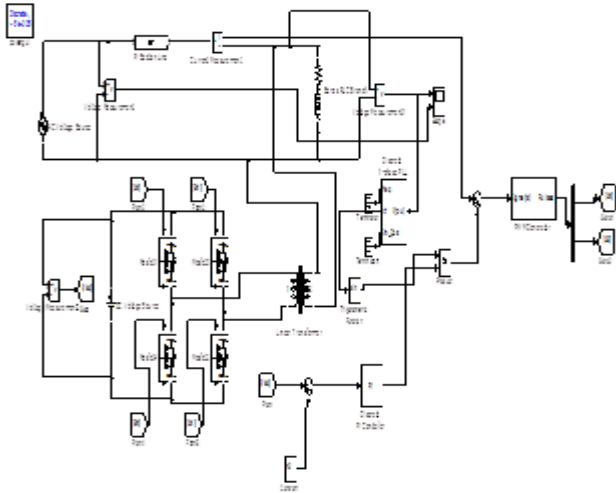

Fig.5. Simulation with D-STATCOM

VI. SIMULATION RESULTS.

Case 1: Given input voltage to the prototype system is 230V and at the output side we get 180 V. So there is difference in input voltage and output voltage that means voltage sag is occurs. We need to compensate the this voltage difference. This can be done by design of D-STATCOM which is nothing but VSI.

Case 2: In this input given to system is 230V and we get the output of the system is 230V. From this we can say that D-STATCOM compensates output voltage by controlling power flow through injection transformer.

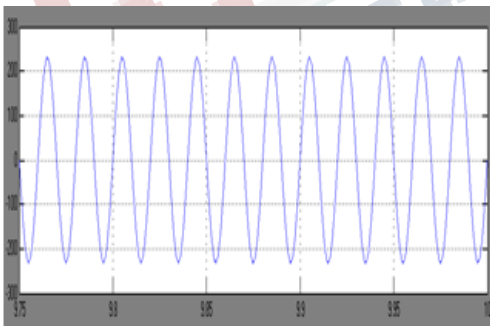

Fig.6. Input to the prototype system

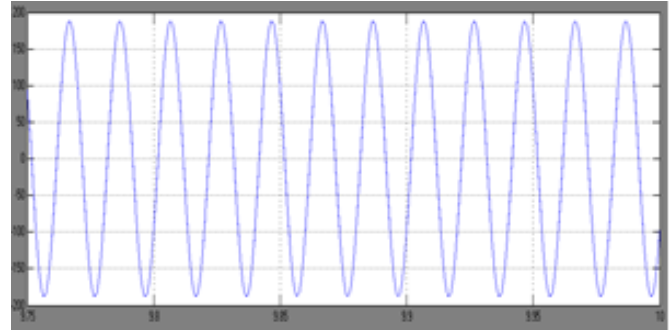

Fig.7. Output Voltage without D-STATCOM

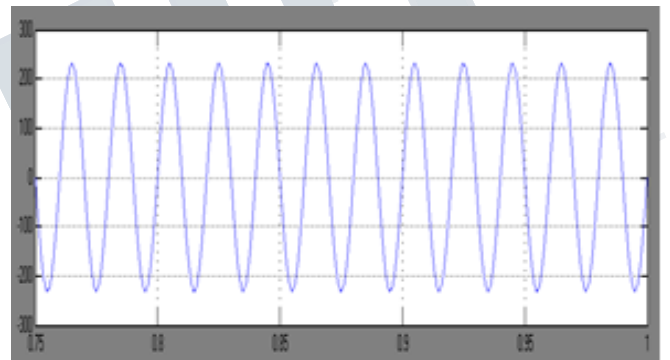

Fig.8. Output Voltage with D-STATCOM

VII. CONCLUSION

A D-STATCOM topology has been proposed in this project, which has the capability of compensating the load at a lower dc-link voltage. The proposed method is validated through simulation for a small prototype model. From this study it is found that the proposed system has low switching frequency, less harmonics, maintain voltage profile, with D-statcom compensation as compare to other convention method.

simulation result will be compare to demonstration for the mitigation in power quality problems.

**International Journal of Engineering Research in Electrical and Electronic
Engineering (IJEREEE)
Vol 3, Issue 2, February 2017**

VIII. FUTURE SCOPE

Custom Power (CP) devices can be used, at reasonable cost, to provide high power quality and improved power service. These Custom Power devices provide solutions to power quality at the medium voltage distribution network level. Control algorithms are described with the help of simulation results under nonlinear loads. PWM control scheme only requires voltage measurements. This characteristic makes it ideally suitable for low-voltage custom power applications.. Extensive simulations were conducted to gain insight into the impact of capacitor size on DSTATCOM harmonic generation, speed of response of the PWM control and transient overshooting.

It is concluded that a DSTATCOM though is conceptually similar to a STATCOM at the transmission level; its control scheme should be such that in addition to complete reactive power compensation, power factor correction and voltage regulation the harmonics are also checked, and for achieving improved power quality levels at the distribution end.

IX. FUTURE WORK

This paper presents a detailed modeling and analysis of one of the custom power device DSTATCOM. Detailed simulations developed models in MATLAB simulink using the sim power system control tool boxes. Now we are posing a challenge to complete If the remaining control strategies which includes the synchronous frame theory, regulation of Bus and DC link voltage, and ANN based Adaline theory .these control strategies are implemented and studied in detail through various simulations then it would be of immense help for the real time implementation of the DSTATCOM across all over the globe. If thrown light on other custom power devices like the Dynamic voltage Regulator (DVR), and Unified power quality conditioner (UPQC), applying different strategies then we can bring a revolution in the control of power in the distribution systems.

REFERENCES

[1] Operation of a DSTATCOM in Voltage Control Mode” by Mahesh K. Mishra, Student Member, IEEE, Arindam Ghosh Senior Member, IEEE, and Avinash Joshi.

[2] A DSTATCOM Topology With Reduced DC-Line Voltage Rating for Load Compensation With Nonstiff Source, IEEE TRANSACTIONS ON POWER ELECTRONICS, VOL. 27, NO. 3, MARCH 2012.

[3] M. Bollen, Understanding Power Quality Problems: Voltage Sags and Interruptions. New York: IEEE Press, 1999.

[4] “Understanding FACTS; Concepts and Technology of Flexible AC Transmission Systems” by N. G. Hingorani, L.Gyugyi

[5] Hendri Masdi1, Norman Mariun.M.Bashi MIEEE, A. Mohamed, SallehYusuf“Design of a prototype D-STATCOM for voltage sag mitigation” in IEEE TRANSACTIONS ON POWER ELECTRONICS, VOL. 20, NO. 9, April 2009.

[6] ArindamGhosh and Gerard Ledwich. “Load Compensating D-STATCOM in Weak AC Systems” in IEEE TRANSACTIONS ON POWER DELIVERY, VOL. 18, NO. 4, OCTOBER 2003.

[7] M.Deepika, Mrs.S.M.Padmaja. “SIMULATION OF D-STATCOM BASED ON 5-LEVEL CASCADED H-BRIDGE INVERTER” in International Journal of Engineering Research & Technology (IJERT) Vol. 1 Issue 5, July - 2012 ISSN: 2278-0181.