

# Solar Power Auto-Irrigation System

<sup>[1]</sup> Vicky Vaidhya, <sup>[2]</sup> Nilesh Vaidya, <sup>[3]</sup> Riyaz sheikh, <sup>[4]</sup> Ashutosh Kharate, <sup>[5]</sup> D. M. Holey  
Department Of Electrical Engineering Nagpur, K.D.K.C.E. NAGPUR, <sup>[5]</sup> Prof

**Abstract:** -- This paper proposes a model of variable rate automatic microcontroller based irrigation system. Solar power is used as only the source of power to control the overall system. The sensor is placed on paddy field and these sensors continuously sense the water level and give the message to the farmer informing the water level without visiting the paddy fields. Thus low-cost solar power can be the answer for all our energy needs. Solar powered smart irrigation systems are the answer to the Indian farmer. This system consists of solar-powered water pump along with an automatic water flow control using a moisture sensor. It is the convenient solution for the present energy crisis for the farmers. This paper reveals a model of automatic micro controller based irrigation system. This paper proposes a model of automatic microcontroller based irrigation system. Here solar energy act as the sole supplier of energy throughout. Sensors are placed on the field and these sensors continuously sense the water level and give the message to the farmer informing the water level without visiting the paddy fields. This paper proposes a model of automatic microcontroller based irrigation system. This system reduces the cost and increases productivity. This system conserves electricity by reducing the usage of grid power and conserves water by reducing water losses.

**Keywords:** — Smart irrigation; solar power; solar pump; moisture sensor; energy crisis.

## I. INTRODUCTION

Solar energy is the most abundant source of energy in the world. Solar power is not only an answer to today's energy crisis but also an environmental friendly form of energy. Photovoltaic generation is an efficient approach for using the solar energy. Solar panels (an array of photovoltaic cells) are now a days extensively used foener running street lights, for powering water heaters and to meet domestic loads. The cost of solar panels has been constantly decreasing which encourage sits usage in various sectors. One of the application of this technology is used in irrigation systems for farming. Solar powered irrigation system can be a suitable alternative for farmers in the present State of energy crisis in India. This a green way for energy production which provides Free energy once an initial investment is made. We propose an automatic irrigation system using solar power which drives water pumps to pump water from bore well to a tank and the outlet valve of tank is automatically regulated using controller and moisture sensor to control the flow rate of water from the tank to the irrigation field which optimizes the use of water.

## II. LITERATURE SURVEY AND BACKGROUND STUDY:

According to the surveyconducted by the Bureau of Electrical Energy in India in 2011 .there are around 18 million agricultural pump set and around 0.5 million new connections per year is installed with average capacity 5HP. Total annual consumption in agriculture sector is 131.96 billion KWh (19% of total electricity

consumption).As solar powered smart irrigation technique is the future for the farmers and a solution for energy crisis. So for the proposed solar powered system we are using techniques analyzed in and modified. Sine PWM technique has been Used for inverter operation for minimum harmonics asgiven which further increases the efficiency of the system The rating of the system was calculated corresponding to the pump specifications referring to paper .

## III. THE PROPOSED SOLUTION:

In this proposed system we utilize the solar energy from solarpanels to automaticallypump water from bore well directly into a ground level storage tank depending on the intensity of sunlight. While conventional methods include pumping of water from borewell into a well and from this well onto field using another pump, our system uses only a single stage energy consumption where in the water is pumped into a ground level tank from which a simple valve mechanism controls the flow of water into the field.

### 3.1 System description:

Proposed irrigation system mainly consists of two modules- Solar pumping moduleand automatic irrigation module. In solar pumping module a solar panel of required specification is mounted near the pump set Then using a control circuit it is used to charge a battery. From the battery using a converter circuit it gives power to the water pump which is submerged inside the well.Then the water is pumped into an overhead tank for storing water temporarily before releasing the water into the field. In automatic irrigation module the water outlet valve of the tank is electronically controlled.

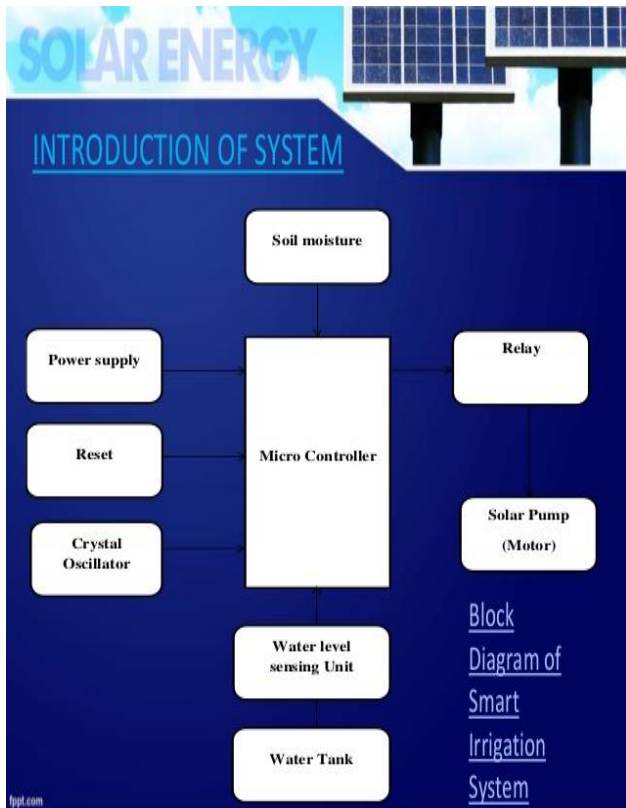

**Fig.1. block diagram of smart irrigation system Implementation:**

For the implementation of the proposed system we are using a 2 HP water pump and Various modules which are designed and fabricated separately and then finally they are assembled together to implement the proposed system. Solar energy harnessed using solar panel PVL-68 that generates 53W at Nominal Operating Cell Temperature. It is 24V, amorphous silicon type solar cell. Specification of the solar panel selected:  
Array capacity --240Wp  
Irradiance – 580W/m Open circuit voltage – 18.1 V Short circuit current – 3.98 A

**IV. DESIGN OF CONVERTER AND BATTERY SPECIFICATION**

An inverter is designed with a DC input of 230V D.C which is generated from 12V D.C using a boost converter. Sine PWM technique is applied to generate 230V A.C. The inverter circuit fabricated is shown in Fig. 4. As far as battery is concerned we are using a battery with 12V, 100Ah capacity for a 2HP pump.

**4.2 Moisture sensor module:**

A moisture sensor is used to sense the level of moisture content present in the irrigation field. It has a level detection module in which we can set a reference value. This circuit can be used with analog probes that produce a voltage proportional to soil moisture such as VG400 probe shown in Fig. 3. The moisture content of the soil is found by using the soil moisture sensor such as VG400 which produces an equivalent output voltage proportional to the conductivity between the two probes.



**Fig. 2: Soil Moisture Sensor probe.**

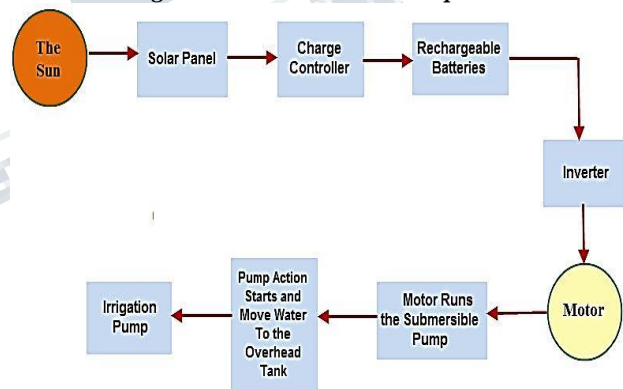

**Fig. 3: solar pumping module**

**4.3 Automatic valve regulation:**

For an automatic valve control we are using a stepper motor as an actuator control of the valve which is connected to the outlet valve of the tank. With the help of moisture sensor signal and a controller, a control pulse is given to the driver circuit that excites the stepper motor. So this way the outlet valve is slowly opened or closed depending upon the amount of moisture present in the soil of the field. When the soil moisture content reaches the required value, the valve is fully closed and power to driver circuit is killed and controller is put into sleep mode for low power consumption.

**International Journal of Engineering Research in Electrical and Electronic  
Engineering (IJEREEE)  
Vol 4, Issue 3, March 2018**

---

### V. COST ANALYSIS

With over nine hundred thousand tube wells being used in every state of India, around Rs.18 Million of energy is used for pumping water for irrigation. This amount of money used for electricity can be saved with the help of solar water pump. Annually the cost of nearly five million kilo watt hour of energy can be spared. That is around Rs.27 Million per annum can be redeemed which comes around 40% of the total amount of investment. Even though the initial investment is high, it can be earned back in 2 and a half years' time. If we assume the cost of power is Rs. 1.5 Million per kilo watt hour, Rs.18 Million is used for pumping water alone in a year. By using the solar water pump, we can save up to 4.8 million KWh of energy annually which saves a lot of energy. The excess energy can also be given to the grid with small modifications and investments in the circuit, which can add to the revenue of the farmer.

#### Advantages:

1. By using the automatic irrigation system it optimizes the usage of water by reducing wastage and reduce the human intervention for farmers.
2. Due to excessive flow of water in the crop, the soil lose it's fertility . So this project will prohibited the lose of fertility.
3. Solar pumps also offer clean solutions with no danger of borehole contamination.

#### DISADVANTAGES

1. LOW Yield : solar pumping is not suitable where requirement is high.
2. Variable Yield: water yield of solar pump changes according to sunlight. It is highest in noon and least in morning and evening. This should be taken into consideration while planning for irrigation.
3. Water quality: As with any other pump, solar pump works best if water is clean, devoid of sand or mud. However if water is not clean, it is advisable to clean the source before installation or use good filter at the end of pipe.

### VI. CONCLUSION

By implementing the proposed system there are various benefits for the government and the farmers. The excess energy produced using solar panels can also be given to the grid with small modifications in the system circuit, which can be a source of the revenue of the farmer, thus encouraging farming in India and same time giving a

solution for energy crisis. Proposed system is easy to implement and environment friendly solution for irrigating fields.

The system was found to be successful when implemented for bore holes as they pump over the whole day. Solar pumps also offer clean solutions with no danger of borehole contamination. The system requires minimal maintenance and attention as they are self starting. To further enhance the daily pumping rates tracking arrays can be implemented. This system demonstrates the feasibility and application of using solar PV to provide energy for the pumping requirements for sprinkler irrigation. Even though there is a high capital investment required for this system to be implemented, the overall benefits are high and in long run this system is economical.

### REFERENCES

- [1] Garg, H.P. 1987. Advances in solar energy technology, Volume 3. Reidel Publishing, Boston, MA.
- [2] Halcrow, S.W. and Partners. 1981. Small-scale solar powered irrigation pumping systems: technical and economic review. UNDP Project GLO/78/004. Intermediate Technology Power, London, UK. A. Harmi metal.
- [3] Mathematical modeling of a box-type solar cooker employing an asymmetric compound parabolic concentrator," Solar Energy, vol.86, pp. 1673–1682, 2012.