Design of Low Cost Dynamic Mechanical Analyzer to Evolve Mechanical Properties of Soft Materials.

^[1] Mr. Salim Jafri, ^[2] Dr. Priam Pillai

^{[1][2]} Department of Mechanical Engineering

^[2] Pillai College of Engineering, University of Mumbai, India

Abstract: -- Dynamic Mechanical Analyzer's (DMA) available today are so advanced with the capability of analyzing multiple material properties within the same system, DMA system is expensive and immobile because of its complex design, sensors and actuators like highly advance strain gauges, load cell and pneumatic, hydraulic, servo electric motor's. Considering the cost as a criteria this paper is an attempt to provide low cost and portable design of DMA for testing soft polymer and viscoelastic material.. The DMA system is successfully designed and fabricated using 3D printed parts, laser cut acrylic and aluminum supports.

Keywords: DMA, Load cell, Strain gauge, Travel bed

INTRODUCTION

The Dynamic Mechanical Analyzer is an instrument to analyze different properties of a material like tensile, compression, flexure, torsion, shear, stiffness by acquiring various parameters like stress, strain, temperature, time, frequency, etc [1], [2].

By going through the process control technology [3] the DMA is designed in order to study the dynamic behavior of viscoelastic material which has varying stiffness at different geometry and strain rates. This DMA can generate static tensile load to measure the stiffness of the material and cyclic tensile load to measure the deformation of materials, as it has limitations due to load capacity of 2 lbs. and deformation range of 50 millimeters (mm). These limitations can overcome just by replacing the load cell, strain gauge and motor according to required capacity, which will allow us to test hard materials, hence allowing us to do compression and shear test even. With little modification in the design it can also do the torsional test for material. As the system design is open without any leak proof chamber, the temperature dependent material analysis [4], [5] can't be done until unless the design is innovated in the future.

The DMA generates tensile force and cyclic load with the help of stepper motor for precise speed control to control the strain rate of material. The dynamic stress data which are acquired from force sensor and strain data from linear variable potentiometer [6] instead highly advanced technology [7] as strain gauge, extensometer, strain

measuring cameras or LVDT to measure the deformation of materials.

Design of Dynamic Mechanical Analyzer:

The DMA is designed as such to measure the stiffness and young's modulus of soft viscoelastic material like soft and delicate polymers. The DMA designed is capable of measuring the stiffness of soft material ranging from 0 to 8 newton's as the force sensor used is of low capacity of 2 lbs (i.e. 8.9 N or 0.91 kg) for the specific purpose of measuring soft materials and it can also measure displacement to maximum 40 millimeter. The range of load and distance of elongation can be changed accordingly by replacing the load cell and strain gauge and by increasing the bed size. DMA works by applying a static deformation to a sample of known

geometry. The sample is subjected to a controlled stress or a controlled strain. For a known stress, the sample will then deform a certain amount. In DMA this deformation is generated by controlling the force motor and is being transmitted to material via a drive shaft. The conventional design explaining different necessary parts and CAD design is as follows:

A. Conventional Design:

The material required, the process and the parameter taken in consideration for designing setup is as follows:

1. Base Plate:

Base plate made from 10 mm acrylic material which can be laser cut easily and is designed to incorporate fixed strain gauge and two aluminum supports distanced with

respect to the travel length allowed by potentiometer (strain gauge). The total length of base plate designed is 300mm in length and 100mm in breadth which includes whole setup into a portable light weight system.

2. Aluminum Supports:

Two aluminum supports are designed in L-shape with a 10 mm aluminum material in order to reduce the vibration which can happen due to stepper motor mounted on it. These supports are drilled in order to place the supports on acrylic base, to hold the motor and load cell. The one side of aluminum is designed to hold load cell horizontally whereas the other side of aluminum supports is designed to hold stepper motor horizontally and to let pass the shaft of stepper motor to connect with drive shaft. Both these aluminum supports are also drilled to align themselves in straight guiding path to guide the travel bed linearly with the help of guide rods.

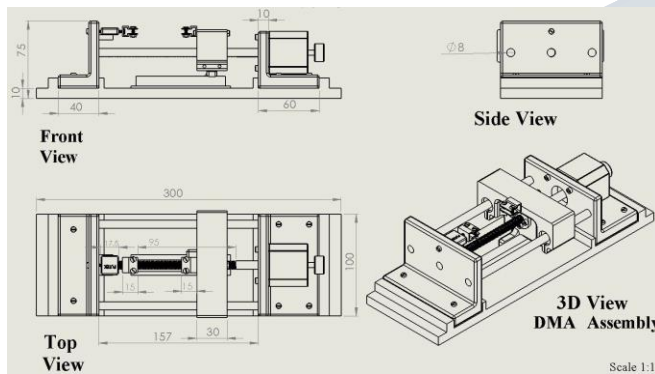

Figure.1 Computer Aided Drafted view of DMA system.

3. Stepper motor:

12 volt stepper motor is used which can produce the torque, enough to generate load according to the capacity of load cell say for 1 kg. The stepper motor is mounted on one side of aluminum support and the drive shaft coupled with motor is supported by the aluminum support on other side aligning it in the center.

4. Drive shaft:

It's a square threaded rod coupled to the shaft of the stepper motor. This shaft is supported by other aluminum support to align the shaft. Shaft helps driving the travel bed linearly back and fro with the help of guide rods hence known as drive shaft. This drive shaft connected

with motor helps generating the force required to deform the material.

5. Load Cell:

The load cell is mounted on Aluminum support. The load sensor is placed on aluminum support as such the gripper attached to load cell gets aligned with movable gripper attached to travel bed. The load cell is placed such there should not be any pre stress applied while mounting it.

6. Fixed Material Gripper:

It's a fixed gripper attached to the load cell to hold material from one side. Paper clip, clamps or any gripper which is supposed to be lighter in weight than the load cell capacity, can be used to hold the material. When the deformation would happen, this fixed gripper will create a force on load cell, hence providing force data to equate against the area to produces stress data.

7. Travel Bed:

The travel bed which has to move linearly and is supposed to be connected to potentiometer and hold the gripper horizontally aligned to load Cell at the same time of traveling linearly with help of guide rods and linear bearings, a fixture is designed and been manufactured by using 3D printing technology, which holds linear bearing on two sides, fixed threaded nut to transfer rotary motion of motor into linear motion and space to hold the gripper aligned horizontally to load cell fixed on the other side of aluminum.

8. Travel Nut:

This nut is fixed in travel bed to convert rotary motion of the motor into linear motion with the help of a side linear bearing inside travel bed constrained with guide rods to move linearly.

9. Material Gripper:

This gripper is attached to the movable travel bed aligned with the fixed gripper. It keeps holding the material while travel bed is moving. Paper clip or any clamp can work which is capable of holding the material with the respective to the load needed by the system.

10. Guide Rod:

Two stainless steel based guide rods are placed between two aluminum supports constraining the movement of a travel bed linearly instead of rotary with the help travel nut fixed in travel bed. These guide rods are supposed to be properly aligned in order to avoid any unstable movement from drive shaft not affecting the linear travel.

11. Linear Bearing:

Designed part of a travel bed requires neither springs nor air-bearings to support the drive shaft. Two linear bearings are placed inside travel bed to create smooth and frictionless travel on stainless steel guide rods.

12. Strain gauge:

Strain gauge is fixed on the base plate with the moving knob connected to movable travel bed. The system is designed with respect to the strain gauge with capacity for measuring deformation of maximum 100 mm, which can be replaced according to requirement easily. This limitation of 100 mm with incorporation of travel bed and gripper limits the system to measure the deformation of 50 mm. This limitation can easily overcome by replacing the strain gauge with higher deformation length.

B. CAD Modeling of DMA:

By taking into considerations all the above parts required and all the conditions to perform uniaxial loading system to measure mechanical properties, a Computer Aided Design (CAD) is prepared in Solidworks as shown in Fig.2. The DMA designed here is system which can be fabricated with low cost material like aluminum supports, stainless steel guide rods, 3D printed travel Bed, laser cut base to hold the support and strain gauge, threaded rod attached to the shaft of controlled stepper motor and guided linearly with the help of guide rods and linear bearings. The compact and lightweight design allows it be portable.

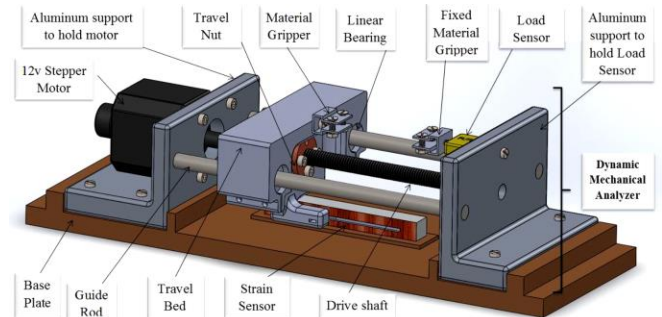

Figure.2 SolidWork Assembly of CAD Model for designed DMA system.

Cost analysis:

The designed parts were fabricated using fused deposition method based ultimaker 3D-printer and aluminium support were fabricated according to design from machine workshop. The cost analysis of acrylic base and other required instrument as discussed above to fabricate the system is as follows:

Part no.	Instrument	Aproximate Cost in Rupees	Part No.	Instrument	Aproximate Cost in Rupees
1	Futek 2lbs load sensor	₹ 31,500	6	Stainless steel Guide rod (2 Psc)	₹ 100
2	Futek Load sensor amplifier	₹ 26,775	7	Linear bearing (2 Psc)	₹ 350
3	10 KΩ Linear Potentiometer	₹ 130	8	Stepper motor	₹ 750
4	Aluminium supports	₹ 600	9	Lead screw rod and nut	₹ 300
5	3D printed travel bed	₹ 300	10	Acrylic base	₹ 100
Total					₹ 60,905

Table.1 Cost analysis of instrument and material required for the system.

CONCLUSION:

This paper gives the complete design of the Dynamic Mechanical System. This design would be a useful experimental setup to evolve the mechanical properties like stiffness and young's modulus of soft polymer's or viscoelastic material. In this paper the design of low cost and portable experimental DMA setup is proposed and fabricated using lightweight materials, 3d Printed parts and replacing expensive DMA components with alternatives like linear potentiometer successfully making it low cost as estimated in cost analysis By creating a control system to control the motor with microcontroller and acquiring dynamic data from sensors using a data acquisition system and simulating it in software like

LabView, the dynamic mechanical properties can easily be studied from proposed design for DMA.

ACKNOWLEDGEMENT:

I am using this opportunity to thank my organisation to provide me with facilities like 3D Printing for making parts of the system, Machine workshop to fabricate various parts and component library for giving access to required electrical component for the project. I also thank Pillai college of Engineering for funding this work.

REFERENCE:

- [1] K.P. Menard, Dynamic mechanical analysis: a practical introduction. CRCpress,2008.
- [2] Y. Gharagozlou, “7 Tips For Materials Testing,” Instron Corporation, Tech. Rep., 08/2015.
- [3] C.D. Johnson, Process control instrumentation technology. Pearson Education Limited, 2014.
- [4] L. Li, “Dynamic mechanical analysis (dma) basics and beyond. parkinelmelmer inc,” 2000.
- [5] M. Instruments, “Metravib DMA 25/50 user’s guide,” Limonest, France, September 2012.,651,123.
- [6] L. P. Zepp, “Linear potentiometer,” Mar. 17 1987, US Patent 4,651,123.
- [7] Y. Gharagozlou, “Strain Measurement Techniques for Composite Coupon Testing,” Instron Corporation, Tech. Rep., 12/2015.